

Lieutenant Colonel Walters, the commanding officer of the 6th Motor Transport Battalion, replaced the least reliable civilian drivers. Despite these problems, Saudi Motors averaged 250 trips a day, moved 50,000 short tons of cargo, and succeeded in stocking Kibrit.³²⁴

At Jubayl, GSG-1 modified weapons systems while at Mishab, GSG-2 opened the port. Taking some of the pressure off Saudi Motors, the MV *Mallory Lykes*, the first ship to venture into Mishab, dropped anchor on 25 January. Dodging FROG missiles, GSG-2 unloaded ammunition, which saved Saudi Motors 500 trips over the distance between Jubayl and Mishab.* From GSG-2, Colonel Hampton pushed ammunition to FASP-3 at Kibrit. On the 27th, an Army ROWPU barge docked at Mishab and three days later began producing water.³²⁵ Unfortunately, some of the millions of gallons of oil that the Iraqis dumped into the Persian Gulf fouled the filters of the Army's ROWPUs, which sucked in raw water from the surface of the Gulf. To counter the problem, the GSG-2 engineers figured a way to draw the raw water from below the surface and kept the Marine Corps ROWPUs operating as the primary source of water in northern Saudi Arabia.^{326**} At Jubayl, GSG-1 worked through Scud alerts and adapted equipment to the situation. Ordnance specialists from the 2d Maintenance Battalion installed applique armor on the 53 M60A1 tanks of the 8th Tank Battalion and helped field new M1A1 Abrams tanks to the 2d Marine Division. Together with a team from the United States, optics technicians modified 476 day trackers and 153 night-sight missile guidance systems on TOW II launchers.³²⁷

To manage the predicted 108,000 Iraqi prisoners of war, General Brabham ordered Lieutenant Colonel Linden L. Sparrow to build and operate a camp near Kibrit, which could temporarily hold as many as 40,000 for collection by the U.S. Army.³²⁸ Sparrow, who reported to Colonel Hampton at GSG-2, began activating CSSD-91 on the 12th, and sent a Reserve military police detachment from Pittsburgh to Kibrit. Joining the military policemen on the 17th, the Seabees of NMCB-5 used a U.S. Army manual to lay out a camp, divided into three holding pens and a processing area. The Seabees dug in tents, built a mess hall, and erected guard towers around a 3,000-foot by 1,500-foot swath of ground.³²⁹

Back at Jubayl, Lieutenant Colonel Sparrow collected people and equipment to operate the camp and sent forward materials to finish building the facility. At Kibrit, working parties of Marines strung concertina wire around the camp to pen in the prisoners. To distribute water in the camp, the CSSD Marines scrounged 500-gallon water tanks from a Saudi company and linked them together with rickety plastic pipes. For prisoner sanitation, the Seabees dug slit trenches and, taking the advice of U.S. Army specialists who were knowledgeable about Arab bathroom behavior, built special wooden heads designed to give the user pri-

*After the Iraqi missile attacks on Mishab, the GSG-2 Marines and sailors referred to the area near the pier as "The FROG Pond." (Hampton comments)

**According to LtCol Skipper, the commanding officer of the 8th Engineer Support Battalion, "From 14 January to 2 March, the Marine ROWPUs produced 3.75 million gallons of potable water." (Skipper comments)

vacy. In the processing area, Sparrow established an assembly line system where prisoners were to be searched, interrogated, checked by a doctor, given a blanket, provided a bottle of water, and fed rice and beans before entering the holding areas. During the process, all personal effects were to be screened, inventoried, and immediately returned, except for weapons and items having intelligence value.³³⁰ On 23 January, the DSC sent CSSD-91 its first three Iraqi patrons, whom U.S. Army specialists processed, held, and shipped south.³³¹

The Direct Support Command

With the ground war scheduled to start in early February, General Krulak continued preparing the DSC to support the 1st and 2d Marine Divisions. Saudi Motors filled the ammunition supply point with 15,800 tons of munitions and the DSC's two hospitals, with 470 beds for potential patients between them, opened nine operating rooms. The well repaired by the Seabees produced 80,000 gallons of water per day, while the DSC's maintenance detachment modified 15 M60 Tanks and 26 bulldozers to perform breaching operations for the divisions.³³² With the construction of Kibrit completed, the burden on the DSC's engineers, who had been working around the clock, eased and allowed them to continue with their innovative preparations for the ground war.^{333*}

Knowing that penetrating the Iraqi minefields was the most critical effort in I MEF's attack, Lieutenant Colonel Skipper, the commanding officer of the 8th Engineer Support Battalion, modified his battalion's D-7 bulldozers for the task. Immediately after the battalion's arrival in December, Skipper ordered his staff to design a way to protect bulldozer drivers from small arms fire and shrapnel, and to devise a wedge to plow through the minefields. The Marines purchased the armor for the protection of the driver from the Saudi economy while Zahaid, the Caterpillar dealer in Jubayl, fashioned a wedge-shaped blade for the front of the bulldozer, similar to the design used by the Israelis and Soviets.^{**} In mid-January, the engineers tested the first armored D-7 prototype which proved partially successful. The operator could hold the heavy blade level without digging it into the sand and the bulldozer engine did not overheat from the extra weight, however, the blades of the wedge were too short. As planned, the forward motion of the wedge pushed the mines to the side of the road, but after the blades passed by, the mines would roll back into the lane. A simple extension of the length of the blades solved this problem and Lieutenant Colonel Skipper ordered four wedges from Zahaid. The engineers called the new armored D-7 bulldozers with the wedge-shaped-blades, "Ninja Dozers."³³⁴

While the DSC prepared to support the attack, the 2d Marine Division deployed north from its positions at the Triangle to assembly areas south of

*LtCol Skipper commented that the blackout ordered by Gen Krulak at the beginning of the air war was "... one of those great ironies of the war..." and "provided a rest period for the 7th and 8th Engineer Support Battalions." (Skipper comments).

**In late January, the Marine Corps Logistics Base, Albany, Georgia, pushed armored kits to Saudi Arabia which protected the D-7 drivers.

Kibrit.³³⁵ After spending only about two weeks at Abu Hadriyah, DSG-2 moved 130 kilometers with the division to a position 70 kilometers south of the Kuwaiti border and 30 kilometers southwest of Kibrit.³³⁶ DSG-2's new logistics support area became known as Hobo Alley and located DSG-2 within DSC's logistic network.³³⁷ Starting on the 23d, the DSC routinely transported 30,000 gallons of fuel, 20,000 gallons of water, and 32 pallets of MREs a day to build-up DSG-2 stocks. The daily supply run, performed by the 8th Motor Transport Battalion, consisted of 18 LVSS which made the 60-kilometer roundtrip from Kibrit.³³⁸ During this period, DSG-2's operations officer, Major Arthur H. Sass, joined the DSG and established support procedures which were nonexistent when the organization formed. Sass developed a CSS customer's service guide which published DSG-2's capabilities.³³⁹ To protect Hobo Alley from enemy air power, Major General Keys, the Commanding General of the 2d Marine Division, sent an anti-air defense team of 13 Marines armed with Stinger shoulder-fired antiair missiles to DSG-2.^{340*}

In preparation for the coming ground offensive, DSG-2 concentrated on increasing the 2d Marine Division's equipment readiness, but ran into problems. The DSG was the first source of repair parts for the 2d Marine Division which overwhelmed the supply detachment with requests.³⁴¹ For example, the 10th Marines placed 14 computer disks worth of requisitions on DSG-2, which lost 12 of the disks.³⁴² Moreover, in the face of the deluge of appeals for support, DSG-2 lacked repair parts in its supply block, which had only 440 of the 1,500 line items needed to support the division.³⁴³ To obtain the needed parts, DSG-2, as well as DSG-1, requested items from the DSC at Kibrit, which either filled the request or passed it on to Jubayl. GSG-1 either issued the item or requisitioned the part from the United States. To further aggravate the situation, automated supply and maintenance reports available in garrison were almost non-existent in Saudi Arabia. This caused units which were ignorant of the status of their original requests to reorder parts multiple times and further overload the system.** To combat the problem, the 2d Marine Division sent a liaison team, which carried copies of the lost 10th Marines requisition disks, to DSG-2 on the 25th and Captain Alan B. Will, DSG-2's supply officer, went to Jubayl to track down the needed repair parts.^{344***} In addition, Major Dalton J. Langlinais, DSG-2's main-

*The 3d MAW originally assigned the Stinger team to the 2d Marine Division. (Donnelly comments)

**The 10th Marines reported an 8 percent fill rate on parts during February 1991. (10Mar ComdC Feb91, Sec 2)

***Capt Will described the supply situation as frustrating. As an example, he related a verbal exchange between himself and the executive officer of one of the artillery battalions, who was checking on the status of his battalion's orders. "I called customer service at Al Jubayl and talked to the officer in charge. They did not have a record of the repair parts request. I informed the XO of that. The XO informed me that I 'better stay on top of the requisitions because his lieutenant was pretty big and played football at the Naval Academy.' I informed the XO that I was pretty good with a pistol. He responded with, 'Captain, I have your grid square.' " (Maj Alan B. Will, comments on draft, 25Nov96, Author's Files)

tenance officer, manually managed the maintenance system, judiciously used parts from broken equipment to fix other items, and was thankful that the division's equipment, much of which came from MPSRon-1, generally was in good condition.³⁴⁵

On the 21st, the Tiger Brigade arrived near Kibrit and significantly enhanced the firepower and mobility of the 2d Marine Division, but increased the logistic burdens on DSG-2. The Tiger Brigade added 4,212 soldiers, 354 tracked vehicles, and numerous trucks, generators, and HMMWVs to I MEF, which had agreed, after numerous meetings with ArCent, to provide food, water, personnel support items, general medical support, and common-repair parts to the Tigers. ArCent had agreed to continue distributing clothing, organizational equipment, ammunition, and Army-unique repair parts to the brigade.^{346*} On the 25th, Colonel Donnelly sent Captain Robert E. Tobin as his liaison officer to the U.S. Army 502d Support Battalion, which provided direct combat service support to the Tiger Brigade.³⁴⁷ The 502d, commanded by Army Lieutenant Colonel Coy Scoggins, began pulling supplies from the DSG, but lacked the trucks to pull and push supplies to the brigade. To make up for the shortfall, the Tiger Brigade requested trucks from ArCent.³⁴⁸

Between 16 and 23 January, the 6th Marines moved north, accompanied by MCSSD-26, which moved in five increments to a position 40 kilometers south of Kibrit.³⁴⁹ Lieutenant Colonel Wittle called the new location RRP Laporte and continued to blend the capabilities of MCSSD-26 with the operational requirements of the 6th Marines.³⁵⁰ In response to a request from his MCSSD commander and in recognition of the need to protect his source of supply, Colonel Lawrence H. Livingston, the Commanding Officer of the 6th Marines, attached a section of TOW missile HMMWVs from the 8th Tank Battalion to MCSSD-26. The TOW detachment gave Wittle the ability to move independently on the battlefield and to respond rapidly to requests for support from the regiment without needing its protection. Besides bolstering the defense, Wittle used the TOWs for reconnaissance and scouting missions.³⁵¹

At RRP Laporte, MCSSD-26 increased and improved its level of combat service support for the 6th Marines which grew in size with the assignment of attachments and direct support units.** During the second half of January, Lieutenant Colonel Wittle, believing that the ground war would soon begin, pressed to fix all equipment, especially the weapons systems belonging to the regiment and its assigned units. Items that could not be repaired were swapped for operational equipment held in either the Prepositioned War Reserve or the Quick Exchange Program.³⁵² The daily amount of supplies delivered to the 6th Marines

* According to Col Donnelly, the relations with the Tiger Brigade were reciprocal: "The Tiger Brigade provided a full communications suite to DSG-2 to integrate communications . . . [and] . . . also provided unique M-1 tank maintenance capability. . . The support provided and received was a tremendous demonstration of interservice cooperation." (Donnelly comments)

**Major units either attached to or in direct support of the 6th Marines were the 8th Tank Battalion, Task Force Breach A, and the 2d Battalion, 10th Marines.

almost doubled, to an average of 13,000 gallons of water, 9,000 gallons of fuel, and 32 pallets.³⁵³ To expedite the refuelling of the growing number of vehicles in 6th Marines, Lieutenant Colonel Wittle adopted the rapid refuelling system developed by CSSD-10. An eight-man team could set up the system from the back of an LVS in five minutes and refuel 60 assault amphibious vehicles in an hour. MCSSD-26 practiced rapid refuelling with the regiment, until it became second nature for both customer and supplier.^{354*} To ensure good communications with the regiment, Lieutenant Colonel Wittle dispatched Captain Scott A. Allen, a supply officer with extensive infantry battalion experience, to act as a roving customer service representative. Allen often returned from a liaison trip with a fist full of support requests.³⁵⁵

Between 17 and 23 January, the 8th Marines, commanded by Colonel Larry S. Schmidt, moved to assembly areas south of Kibrit. On the 22d, Lieutenant Colonel Head relocated MCSSD-28 to a position 30 kilometers southeast of the DSC and 14 kilometers due east of the regimental command post. At the assembly area, MCSSD-28 continued to focus on refining tactical movement, security, and resupply capabilities. MCSSD-28's operations officer, Major James M. McNeal, and Captain Tony L. Bumgarner, the tactical security officer, conducted intensive day and night tactical movement and resupply exercises that honed the mobile's ability to support the 8th Marines.³⁵⁶ On the 29th, the 1st Battalion, 8th Marines, and the 2d Battalion, 4th Marines, received detachments from the 2d Assault Amphibious Vehicle Battalion while the 3d Battalion, 23d Marines, obtained 32 5-ton trucks from the 4th Truck Company. The addition of trucks and amphibious assault vehicles made the regiment fairly mobile, but increased the amount of fuel and maintenance support required from MCSSD-28. In addition, the number of trucks allocated to the 8th Marines was not enough to accomplish its mission, a shortfall which hampered rapid movement and caused the regiment to look to MCSSD-28 for help.³⁵⁷

During this period, on 25 January, Colonel Powell, the DSG-1 commander, published his plan to move 110 kilometers northwest to Al Qarrahto in support of the 1st Marine Division. This was the location that the DSC had surveyed in December and found littered with dead camels. Colonel Powell intended to stage enough supplies near the division's assembly areas to sustain the assault deep into Kuwait. To accomplish this goal, Powell ordered CSSD-10 to establish a combat service support area at Qaraah, provide direct support to elements of Task Force Shepherd, the division's screening force along the border, and to continue its general support mission. In order to execute the plan with the limited amount of available trucks, Powell ordered CSSD-10 and the recently activated CSSD-13 to start immediately shuttling people and equipment to the new location ahead of the division.³⁵⁸

*Maj Warker added that resupply procedures were explained and practiced night and day with each of the supported units. This would entail defined security measures for entry into supported units defensive perimeters or designated resupply grid coordinates: "We would attach chemical lights to fuel nozzle points, resupply vehicles with MREs, and water points when in the 'Jiffy Mart' mode." (Warker comments)

Colonel Powell had established CSSD-13 to support Task Force Taro, which was the 1st Marine Division's third maneuver element. General Myatt ordered Taro, commanded by Colonel John H. Admire, to conduct a helicopter assault and capture MEF Object A, the Al Jaber Air Base in Kuwait.³⁵⁹ Colonel Admire moved Task Force Taro, which consisted of the three lightly armed organic battalions of the 3d Marines to Ras Al Mishab where the brigade trained for its heliborne assault. A detachment of Reserve landing support specialists from Company B, 4th Landing Support Battalion, 4th FSSG, Lathrop, California, had joined Taro on 14 January, and began training with the task force.³⁶⁰ Five days later, Captain Ritchie had activated CSSD-13 at Mishab by combining the Reserve Marines and a group of active duty red-patchers from CSSD-141.*

Prior to activation, Captain Ritchie constructed a table of organization for eight officers and 178 enlisted Marines, but was only able to collect four officers and 76 enlisted men, together with a limited amount of equipment.³⁶¹ Because of the lack of people, CSSD-13's landing support specialists instructed and supervised Taro's Marines, who performed the labor-intensive chores of hooking external loads to helicopters and providing landing zone security, functions normally performed by fully staffed landing support organizations. Even with the training, Taro's Marines were uneasy with the idea of dangling their equipment and supplies underneath, and preferred to load things inside the aircraft to enhance speed and maneuverability of the helicopters. To counter this concern, Ritchie pointed out that external loads were designed to deliver supplies and equipment to landing zones quickly while minimizing the aircraft exposure to enemy ground fire. For equipment, CSSD-13 gathered nets and slings, an LVS, two 5-ton trucks, and a couple of HMMVWs. The lack of forklifts in the landing zones during the initial phase of the planned heliborne assault, forced Captain Ritchie to create man-portable supply packages. For example, CSSD-13 used bottled water in boxes instead of 500-gallon bladders and packed medical supplies in ammunition cans.

Captain Ritchie and First Lieutenant Darryl L. Smith, the CSSD's landing zone support area officer, formed a helicopter support group to coordinate landing support operations during the assault. To control HST operations at each landing zone, CSSD-13 would send receiving teams with each of the two assault battalions and a third group with the reserve battalion to unload helicopters, set up supply dumps, and evacuate the wounded. Ritchie planned to lead the receiving team of the first battalion into Al Jaber, while Smith intended to run the departure landing zone.³⁶² The lieutenant wanted to place CSSD-13 next to CSSD-10 in order more easily to obtain supplies and to be near an airfield or FARP to maximize helicopter flight time and availability. Smith prepared to package water, fuel, MREs, ammunition, and medical supplies to maximize delivery during the first helicopter wave, since it was doubtful that subsequent waves would reach the objectives. Captain Ritchie sent to Qaraah his engineer officer and elements of

*These Marines belonged to Company C, 1st Landing Support Battalion, 1st FSSG, which was commanded by Capt Burke during Desert Shield. Burke commanded these Marines in CSSD-141 where they had trained extensively with Task Force Taro at the Cement Factory Ridge. (Burke comments)

CSSD-13 to find a suitable place for staging.³⁶³

On the 26th, Lieutenant Colonel Kelly led CSSD-10's security detachment and engineers together with a group from CSSD-13, headed by Captain Sione L. Kava, a Reserve engineer officer from the Pacific island of Tonga, to Qaraah to establish combat service support areas.³⁶⁴ This movement relocated both CSSDs near the border well in advance of the 1st Marine Division's main body.³⁶⁵ Faced with the conflicting tasks of moving CSSD-10, supporting the division from two locations, and assisting the division reposition, Kelly relocated his CSSD in increments which took five days to complete.³⁶⁶ Major Lucenta, the CSSD's operations officer, who planned the complex relocation, calculated that CSSD-10 needed 300 LVS-loads to move, but only possessed 70 dragon wagons to accomplish its mission.³⁶⁷ The gravel plains at Qaraah were located near a dirt air strip, 40 kilometers southwest of the heel of Kuwait, and east of a desert road that ran north to the border and south to the Kibrit road. Only Task Force Shepherd and elements of the 1st Battalion, 25th Marines, lay between the border and CSSD-10. Less than a week earlier, DSC's 7th Engineer Support Battalion built a mock combat service support area at Qaraah as part of I MEF's deception plan.* On arrival, CSSD-10's engineers worked around the clock to expand the existing berms and bunkers into to a real combat service support area that would eventually cover 10 square kilometers.³⁶⁸ Moving near the airfield and closer to the border, Captain Kava set up a staging area to send supplies by helicopter to Task Force Taro.³⁶⁹ On the 27th, the 8th Motor Transport Battalion began pushing water, fuel, and MREs to both CSSDs.^{370**}

Iraq Attacks Near Qaraah and Khafji 29-31 January 1991

Khafji was one of a series of border engagements at the end of January that took Schwarzkopf and his top commanders completely by surprise.³⁷¹

On 27 January, two U.S. Air Force F16 Fighting Falcon multi-role jet aircraft attacked a motorcade near the southern Iraqi city of Basrah and just missed

*MCSSDs -11 and -17 planned to participate in a deception plan that would simulate a logistics buildup north and west of the "elbow." Neither organization executed the plan. The "elbow" was the point, 70 kilometers inland from the Persian Gulf, where the east-west Saudi-Kuwaiti border turned northwest. (Winter comments); GSG-1's air delivery platoon conducted air drops along the border as part of the deception operations. (1st FSSG ComdC Dec90-Feb91, Sec 2)

**During this period, the 1st Marine Division conducted the first two combined arms raids of the war. CSSD-10 sent food, fuel, and water to support the raids, while DSG-1 coordinated the heavy equipment hauling capabilities provided by the DSC's 8th Motor Transport Battalion. (Col Richard Kelly intvw, 10Apr96, (Oral HistColl, MCHC, Washington, D.C.); Col Thomas S. Woodson intvw 19Mar96 (Oral HistColl, MCHC, Washington, D.C.); DSG-1 ComdC, Jan 91; 8th Motor Transport Battalion Dispatch Log, 22Jan91)

killing Saddam Hussein. The infamous dictator of Iraq was returning to Baghdad after reviewing plans for a surprise attack on Saudi Arabia. Saddam intended to inflict casualties on the coalition forces, humiliate the Saudi military, and stir up political opposition to the war in the United States. The Iraqis aimed to launch the *3d Armored Division* across the border south of Al Wafra, where it would swing east to capture the Port of Mishab. The *1st Mechanized Division* would protect the right flank of the attack by crossing the border above Qaraah, and the *5th Mechanized Division* would leap across the border on the left and seize the Saudi town of Khafji, just 35 kilometers north of the attack's objective, the Port of Mishab. The Iraqi *III Corps Headquarters* would coordinate the attack, which was scheduled for 29 January.³⁷²

Just south of Al Wafra on the 29th, Colonel Stephen A. Tace, the DSC operations officer, led a survey team to look for a location to establish a transfer point.* General Krulak wanted a spot as close to Kuwait as possible where the DSC could stock two days of supplies to sustain operations in Kuwait. After scouting the area along the border, the DSC team drove to Kibrit, without incident, but planned to return to the border the next day to complete the survey.³⁷³ Arriving at his office, Colonel Tace called the MEF G-4 to discuss some routine business and was told to grab his helmet and flak jacket and to get out of the area because Iraqi armor was bearing down on Kibrit. Tace raced to the combat operations center, thinking along the way about the huge roman candle Kibrit would make if the Iraqis blew up its 15,800 tons of ammunition and 1.8 million gallons of fuel. At the operations center he tuned in to the 2d Marine Division's command net and pieced together the situation. The Iraqis were indeed attacking along the border and Kibrit was in danger.³⁷⁴

General Krulak had always been concerned that the Iraqis would learn about Kibrit, attack the exposed base, destroy the MEF's ammunition, and dislocate the offensive.** After learning about the Iraqi mechanized attack, Krulak feared that the middle prong of the assault was indeed aimed at Kibrit. Krulak ordered a 100 percent alert and focused the DSC's defense, which consisted mainly of AT-4 hand-held anti-tank launchers and small arms. Every Marine, male and female, rapidly responded to the crisis, grabbed his or her weapon, and took a place on the hastily formed defensive line. The Saudi and Qatari force to the north that supposedly protected the DSC from attack, had departed the area and left the Americans to their own resources.*** Around midnight, the Marines of CSSD-91,

*Other members of the survey team were Col Donnelly, the DSG-2 commander LtCol Thomas S. Woodson, the commanding officer of the 8th Motor Transport Battalion and LtCol Charles O. Skipper, the 8th Engineer Support Battalion commander.

**Gen Krulak commented that "General Boomer made a tremendous decision, a very brave decision to move his combat service support forward, . . . the one thing that probably should have been done, that wasn't, was to bring some forces up with him." (Krulak Comments)

***The Qatari and Saudi forces were responsible for screening the area north of the Kibrit-Mishab road to the Saudi-Kuwait border. (Krulak comments)



Photo courtesy of LtGen James A. Brabham, Jr.

Diagram shows Iraqi incursions of 29 January. Saddam Hussein intended to start the ground war with a three-pronged attack into Saudi Arabia. These attacks threaten CSSD-10 at Al Qaraah, the DSC at Kibrít, and GSG-2 at Mishab.

who were closer to the border than the DSC, put all of their shotguns, rifles, and machine guns into a pile, blew them up with C-4 explosives, and then fell back to Kibrít to avoid capture. Krulak sent other troops to the road to guide the CSSD-91 personnel into CSSA-1.*

Having no substantial combat power in front of his position, General Krulak called General Keys and requested help from the 2d Marine Division.** Keys immediately dispatched a company of M1A1 tanks from the Tiger Brigade to protect the base.³⁷⁵ At the 8th Motor Transport Battalion's motor pool, which lay north of the ammunition dump, the 29th was a pitch-black night made even

*Gen Krulak commented that there was a good lesson to be learned from CSSD-91's retreat. He said: "These are the kinds of stories that rarely get out, but its those types of things that, we as Marines, need to think about. When you make the decision to put your forces far forward, with minimal protection, then you need to understand that there are dangers involved with that." (Krulak comments)

**During the night of the 29th, normal communications between the DSC and the 2d Marine Division were down. Gen Krulak's driver, Sgt Slick Olson, used his Position Location Reporting System (PLRS) to establish a link with the division's combat operations center. Krulak then requested support from the 2d Marine Division. (O'Donovan comments); Additionally, the DSC used MCSSD-26 as a communications link with the 6th Marines in order to confirm enemy sightings and friendly unit locations. (Warker Comments)

more jittery for the Marines by the false alarm of an Iraqi gas attack. Not aware of the Iraqi armored attacks, but acutely sensitive to the battalion's closeness to the border and the danger to his troops if the nearby ammunition dump went up, Major Edwin Fielder, Jr., the battalion operations officer, was wide awake at the combat operations center. He became even more concerned when he heard the sound of unidentified tanks clanking by his position in the dead of night. After listening to the tanks for a moment and talking with the DSC, Fielder decided that the tanks were friendly since they were moving north and away from Kibrit. Indeed, the tanks heard by Major Fielder were from the Tiger Brigade moving to protect the DSC.^{376*}

Leaving Qaraah on the 29th, Lieutenant Colonel Kelly drove to CSSD-10's rear location inside the Triangle at Crusher Road. Upon arrival there, he learned from the 1st Marine Division's tactical and intelligence nets that an Iraqi armored column was staging in southern Kuwait for a possible attack on either Kibrit or Qaraah. Kelly immediately ordered all AT-4s, LAAWs, crew-served weapons, and ammunition gathered and loaded for an emergency run to the latter position. The CSSD's chaplain organized a three-truck convoy which sped towards the border. Arriving after dark, Kelly deployed all of his Marines along the berms protecting the CSSD. Captain Dennis Muller's lightly armed, but superbly trained security detachment anchored the defense. Brigadier General Thomas V. Draude, the 1st Marine Division assistant commander, joined CSSD-10 to monitor the situation and provided some reassurance to Kelly and his defending Marines that they were not alone. CSSD-10 remained on the berm for the remainder of the night, moved in and out of chemical defense levels 2 and 3 (MOPP-2 and 3), and watched flashes in the sky above the battle raging just a few kilometers north, along the border at Observation Post 4 (OP-4).^{377**} CSSD-10 did not engage the Iraqis, but, the 3d MAW Super Cobra attack helicopters killed two T62 tanks less than two kilometers from CSSD-13.³⁷⁸ The next morning, Kelly dispatched the graves registrations section to recover 11 Marines killed by friendly fires in two separate incidents and ordered Major Lucenta, CSSD-10's operations officer, to continue building Qaraah.³⁷⁹

One hundred kilometers to the east near Mishab, Captain Ritchie, the CSSD-13 commander, received a surprise request from Task Force Taro to push

*Before moving into protective positions, the Tiger Brigade drew tank ammunition from the DSC's Ammunition Supply Point. (O'Donovan comments)

**The higher the MOPP Level the greater the threat of chemical attack. There are four levels of MOPP—Mission Oriented Protective Posture—which require the wearing of different protective items of clothing.

Level 1: Consists of wearing a protective suit (trousers and jacket and carrying boots, gloves, and mask with hood).

Level 2: Adds the overboots to be worn with the gloves and mask, with hood still to be carried.

Level 3: Adds the wearing of the mask and hood.

Level 4: Requires the wearing of the entire outfit, including the gloves. (Quilter, *With I MEF*, p. 96)

immediately enough fuel, water, MREs, and ammunition for an infantry company, and 50 TOW missiles, to the Saudi border town of Ras Al Khafji.³⁸⁰ On the night of the 29th, a brigade from the Iraqi *5th Mechanized Division* crossed the border from Kuwait, captured Khafji, trapped two reconnaissance teams from the 1st Marine Division, and threatened Mishab and Kibrit.³⁸¹ In response to the Iraqi invasion, Arab forces from the Joint Forces Command East moved towards Khafji to retake the town. Upon hearing of the Iraqi attack, Colonel Admire dispatched two combined anti-armor teams (CAAT), an artillery battery, and two TOW sections to assist coalition forces retake the town and requested combat service support from CSSD-13.³⁸²

At Mishab, Captain Ritchie had a number of problems to overcome before honoring Colonel Admire's request. His newly formed CSSD was designed to provide helicopter support and was not equipped to provide ground support. In addition, half of CSSD-13 was at Qaraah. Notwithstanding the drawbacks of the situation, Ritchie immediately requested a refueller from DSG-1 which misinterpreted the request as a permanent equipment transfer to Task Force Taro and refused to send the refueller. The DSG recommended that Taro obtain its refueller from GSG-2. Instead, Captain Ritchie enlisted the help of friends in the 7th Engineer Support Battalion. They gave him a 500-gallon fuel bladder and a pump, and buddies in the 7th Motor Transport Battalion lent him a trailer to haul ammunition. At FASP-3, the ammunition technicians refused to issue munitions to CSSD-13. Frustrated, Captain Ritchie drove home the point that Mishab, to include its ammunition supply point, was now within Iraqi artillery range. Convinced by Captain Ritchie's irrefutable logic, the technicians finally honored the CSSD-13 request.³⁸³

After collecting equipment and supplies, Captain Ritchie hustled his two-truck supply convoy towards Khafji.³⁸⁴ Arriving on the evening of the 30th, CSSD-13 set up a refueling point less than three kilometers south of the Iraqi-held town along the coastal highway and just north of the point where Taro had planted explosives to cut the road, if forced to withdraw. Ritchie's mini-mobile parked directly behind Taro's forward CAAT teams, which were dangerously low on fuel and close to the enemy. Ritchie spent the next 14 hours refueling and distributing MREs and bottled water to the CAAT teams which sent vehicles back for fuel and resupply, as the situation allowed.³⁸⁵ At noon on the 31st, Task Force Taro withdrew its CAAT teams after Saudi and Qatari forces recaptured Khafji and rescued the 12 reconnaissance Marines.³⁸⁶ CSSD-13, totally depleted of supplies, withdrew with the CAAT teams after successfully accomplishing its unexpected mission.³⁸⁷

After the Iraqi attack on 29 January, General Keys ordered the 6th Marines to move to positions 40 kilometers northwest of Kibrit and 26 kilometers south of the border to screen I MEF against further Iraqi probes into Saudi Arabia.³⁸⁸ On 30 January, Colonel Livingston, the regimental commander, rapidly deployed two mechanized battalions; the 2d Battalion, 10th Marines; a company from the 2d Tank Battalion; and a portion of MCSSD-26 near the Kuwaiti border.³⁸⁹ When the word came to deploy, Lieutenant Colonel Wittle rapidly gath-

ered together all available fuel, water, and MREs and traveled north with the regiment. When a vehicle broke down, Wittle took the majority of the convoy forward while leaving a small group behind under the command of Captain Peter M. Warker.* After dark and after fixing the broken vehicle, Warker followed the tracks from Wittle's convoy to find his new location. Along the way, an unidentified mechanized force rapidly approached the little convoy from both sides creating a very dangerous moment. Knowing that both friendly and enemy units were in the area, Captain Warker tensely held fire and was relieved when a Saudi soldier "popped out" of one of the approaching armored vehicles and identified himself. After the encounter with the Saudis, Warker's group joined Lieutenant Colonel Wittle, who arranged the whole convoy into a circular defensive position. The Marines of MCSSD-26 spent the remainder of the night at MOPP-3, nervously listening to unidentified mechanized sounds passing just outside of visual and thermal sight range.³⁹⁰ Wittle named the new location RRP Brown and was joined by the remainder of the CSSD over the next two days.³⁹¹

The Iraqi attacks caused General Myatt, the 1st Division commander, to order Task Force Ripper to prepare a counterattack and the 4th Marines to move to Qaraah. At 2000 on the 30th, Colonel Fulford, the task force commander, directed his battalions to prepare to advance and to smash any Iraqi forces moving towards Khafji. Accordingly, Captain Winter ordered MCSSD-17 to be ready to move north in support.³⁹² At noon on the 31st, the crisis at Khafji passed and Ripper and MCSSD-17 relaxed and remained in position. To be ready for a repeat Iraqi performance, Captain Winter conducted a route reconnaissance to Khafji.³⁹³

In the meantime, on the 30th, the 4th Marines, since 22 January under Colonel James A. Fulks, the former 1st Division operations officer, had rushed to Qaraah with the mission of defending the border area from further Iraqi aggression.³⁹⁴ The 4th Marines was the division's newly formed fourth maneuver unit, consisting of the headquarters element detached earlier in the month from the 1st FSSG; the 2d Battalion, 7th Marines; and the 3d Battalion, 7th Marines. The 11th Marines assigned the 3d Battalion, 12th Marines, to provide direct artillery support.³⁹⁵ To Colonel Powell, the DSG-1 commander, the 4th Marines was an additional burden that further overloaded his already strained ability to support the division. Until a plan could be devised to support the regiment, CSSD-10 would provide supply point distribution.³⁹⁶

In the final chapter of the Kafji battle, Captain Stephen H. Negahnquet, the platoon leader for the Explosive Ordnance Disposal (EOD) Platoon, 8th Engineer Support Battalion, sent Gunnery Sergeant Mickey Scholfield, Staff Sergeant Rydel, and Sergeant Michael R. Glass to Khafji to help clear unexploded ordnance. On 3 February, Scholfield and his team entered Khafji and linked up with engineers from the Saudi Arabian National Guard. Over the previous days, the Saudis had sustained 18 casualties while attempting to clear the vast amount of booby traps, unexploded ordnance, and arms caches that littered the area. The Marine EOD team ducked sporadic sniper, small arms, and artillery fire and

*Capt Warker was MCSSD-26's logistics officer until 4 February, when he became the mobile's operations officer. (MCSSD-26 Historical Collection)

cleared duds, booby traps, a few houses, and some Iraqi armored personnel carriers during the remainder of the day. The next day Chief Warrant Officer 2 Thomas A. Crawford arrived with three NCOs from the 7th Engineer Support Battalion, took charge of the clearing operation, and attached the EOD technicians to squads of Saudi engineers. The U.S./Saudi teams again dodged the intermittent sniper fire and continued with the clearing mission. The following day, Captain Negahnquet and Chief Warrant Officer 3 Thomas E. Bathory arrived at Khafji to supervise the final disposal effort. On the 7th, the Marine EOD team completed its tasks in Kafji, where it destroyed about 4,000 pieces of ordnance, cleared nearly 80 armored vehicles, and gathered many items having a technical intelligence value.³⁹⁷

Conclusion

*Set MOPP level two at 2145, downgraded to MOPP level 0 at 0630.*³⁹⁸

January ended with I MEF taking a deep breath after the Iraqi attacks across the border, continuing the air war against Iraq, and preparing for the ground war. On the 31st, General Krulak was close to reaching the goal of stocking seven days of supply at Kibrit to support the MEF and DSG-1 set up positions near the Kuwaiti border to sustain the 1st Marine Division. General Brabham kept Saudi Motors on the road and pushed ammunition to Kibrit from Jubayl and the newly opened port of Mishab. MWSG-37 pumped oceans of fuel to 3d MAW's attacking aircraft and together with the Seabees, prepared to support the relocations of the 3d MAW helicopters to northern locations. It was apparent to all, that the ground war was about to begin.

Flexibility and Forward to Attack Positions: 1-23 February 1991

Moving to the Attack

Many of the problems experienced during January carried over to February. Transportation issues seemed to overshadow other concerns due to the vast amounts of supplies, equipment, and personnel that needed to be moved. — Col Alexander W. Powell

At the beginning of the month, I MEF continued to prepare for the single-division penetration of Kuwait. General Moore pushed the 3d MAW's operations north; the 1st Marine Division staged its mechanized units near qaraah and conducted combined arms raids along the Kuwaiti border; and the 6th Marines guarded the border south of Al Wafra. The DSC completed stocking Kibrit for the attack and

Table: Combat Service Support overview on 31 January 1991

Location	Logistic Unit (s)	Supported Unit (s)	Distance From Border (Kilometers)
RPP Brown	MCSSD-26	6th Marines	20
Qaraah	CSSDs-10/13	1st MarDiv	30
Kibrit	-DSC -CSSD-91 -NMCB-5 NMCB-40	-Forward Battle Area -I MEF EPW -I MEF	50
Mishab	-GSG-2 -MWSS-273 NMCB-74 NMCB-24	-I MEF -MAG-26	50
Hobo Alley	DSG-2	2d MarDIV	70
Safaniya	3d NCR	I MEF HQ	70
South of Kibrit	MCSSD-28	8th Marines	80
Tanajib	MWSS-271 CSSD-132	MAG-16	90
Jubayl Naval Air Facility	MWSS-374 CSSD-132	3d MAW HQ MAGs 16&26	195
Port of Jubayl	1st FSSG -GSG-1	I MEF	210
King Abdul Aziz Naval Air Station	MWSS-37 MWSS-174	MAG-13 (Fwd)	220
Shaikh Isa	MWSS-373 CSSD-131	MAG-11	360

transported supplies to the DSGs which in turn distributed supplies to the MCSSDs which directly supported the assault forces.

During the first two days of February, Task Force Papa Bear tactically moved 100 kilometers northwest from its positions at the Triangle to an assembly area near qaraah.³⁹⁹ Captain Burke, the commander of MCSSD-11 in support of Papa Bear, used the road march to train with the 1st Division task force and to validate its daily fuel consumption. On the night before the move, Burke sent his refuellers to top off fuel tanks and then dispatched his eight-point rapid refueling systems to establish a forward refueling point. On the 1st, Papa Bear quickly and smoothly filled up at the enroute refueling point and continued its road march. That evening, while the mechanized force halted, MCSSD-11's refuelers again topped it off. The next morning, the MCSSD sprinted for qaraah along the road while the Task Force maneuvered cross country to its new location. After Papa Bear reached qaraah and established defensive positions, Captain Burke distributed food, water, and fuel to its battalions. Burke not only wanted to ensure that the task force was logistically ready to fight now that they were close to the border, but, also, to record the fuel data from the last leg of the journey. With the fuel figures from the road march, Captain Burke calculated Papa Bear's daily consumption rates which he used to plan for the attack.⁴⁰⁰

During the early morning hours of 2 February, U.S. Navy aircraft mistakenly bombed Battery S, 5th Battalion, 11th Marines, 30 kilometers north of qaraah, killing one Marine and wounding two others. Since helicopter medevac was not available, the wounded Marines were evacuated through qaraah to the DSC at Kibrit. CSSD-10's Graves Registrations Platoon processed the dead Marine.⁴⁰¹

The artillery battery was on its way back from one of the combined arms raids that both divisions had conducted along the Kuwaiti border. Following this incident, the 1st Marine Division conducted a number of these raids in which CSSD-10 provided supply support and DSG-1 arranged heavy equipment transportation with the DSC. Colonel Powell, the DSG-1 commander, believed the raids gave his Marines experience in rapidly supporting combat operations and working closely with the division.⁴⁰²

On 3 February, Task Force Ripper and MCSSD-17 moved 110 kilometers to positions south of Papa Bear near the intersection of the Kibrit and qaraah roads. The new location was 60 kilometers south of the border and 50 kilometers west of Kibrit. Upon arrival, Ripper sharpened its breaching skills, rehearsed its planned attack on the Al Jaber Air Base, and launched a small operation against the Iraqis. Captain Winter, the MCSSD-17 commander, took advantage of Ripper's simulated breach lanes by evaluating the trafficability through them and adjusting accordingly his truck loads and equipment.

At the new location, Reservists from Company C, 1st Battalion, 25th Marines, commanded by Major Joseph W. Lydon, joined Ripper to manage prisoners of war who might be captured during the assault. Lydon lacked transportation for his Marines and appealed to MCSSD-17 for assistance. Prior to the war, Captain Winter had been the Inspector-Instructor of the Reserve unit in New

Haven, Connecticut, and had trained with Lydon's company which was from nearby Plainville, Connecticut. Winter agreed to haul some of the Reserve infantry which would give the mobile additional protection against pockets of any hostile Iraqis bypassed by the Task Force during the attack.

In another action following the northward deployment and illustrating the mobile's close working relationship with the task force, Ripper's Tactical Air Control Party and the 3d Tank Battalion had moved another 100 kilometers north to Observation Post 6, where they controlled an air strike against Iraqi positions in Kuwait. MCSSD-17 provided a small convoy carrying fuel, water, MREs, and tank ammunition to support the operation.⁴⁰³

Also moving north with the MEF, the 3d MAW deployed units closer to the border to support the coming ground attack. MWSG-37 continued to prepare Mishab and Tanajib for MAGs-16 and -26 and to help relocate both helicopter groups in their new locations. Colonel Coop, the MWSG-37 commander, formed a provisional truck company with assets gleaned from within the support group. First Lieutenant Thomas L. Hankinson led the MWSG truck company which eventually grew to 30 vehicles.⁴⁰⁴ On 3 February, the MV *Ciudad De Manta* docked at Mishab with a load of AM2 matting that MWSS-273 began laying at the port and MWSS-271 started placing at Tanajib. The following day, MAG-26 began arriving at Mishab, while at Qaraah, MWSS-273 established a FARP to support helicopter operations during the ground assault. To assist General Myatt, the 1st Division commander, Colonel Coop collected D-7 bulldozers from his squadrons and transferred them to the division. At Tanajib, General Brabham activated CSSD-133, commanded by Captain Eric R. Junger, to support MWSS-271 and MAG-16. On the 9th, elements of MWSS-174 from King Abdul Aziz Naval Air Station joined MWSS-271 at Tanajib and set up a support area for AV-8 Harrier Jump Jets. Operating Harriers from Tanajib reduced the distance to the border and allowed the attack jets to rearm, refuel, and return quickly to the battle.⁴⁰⁵ At the Jubayl Naval Air Facility, the wing headquarters, MWSS-374, continued its support of operations there under the command of Lieutenant Colonel Brian E. Dyck, who at the beginning of the month replaced Lieutenant Colonel Stephen G. Hornberger.⁴⁰⁶

I MEF Changes Its Plan

For the logisticians, the war didn't begin on G-day-24 Feb-with the start of the ground assault; it really began about three weeks earlier, when General Boomer decided to breach the Iraqi defenses in two places with two Marine divisions, instead of a single breach with one division. —BGen Charles C. Krulak

The Decision

On 4 February, General Krulak visited MCSSD-26 near the border and decided to stop by the 2d Marine Division command post on his way back to

Kibrit. Krulak found General Keys, the division commander, in a meeting with General Boomer; Colonel Ronald G. Richard, the division operations officer; and Colonel Donnelly, the DSG-2 commander. Boomer greeted Krulak and immediately asked him his opinion about a proposal that General Keys had made to conduct a two-division breach of the Iraqi defenses as opposed to a single penetration. Krulak replied that he favored the recommendation for a number of tactical reasons and believed there was enough mine-clearing equipment to support the concept. On the map, General Boomer showed the DSC commander a spot west of Kuwait, located about 150 kilometers from Kibrit and asked him, "the \$64,000 question—Can you support a two-division breach on the western flank of Kuwait?" While having some internal doubts, Krulak swallowed hard and answered the MEF commander, "I know I can't support that from Kibrit. I need to find another location for the combat service support area."⁴⁰⁷ Boomer replied that he was still undecided, but ordered the DSC commander to find a location and to prepare an estimate of supportability for Keys' plan.

Immediately upon his return to Kibrit, General Krulak gathered his key personnel and planned to find a new location to support a two-division attack. After briefing the group on the situation, Krulak ordered Colonel Gary S. McKissock, who was on loan to the DSC from II MEF where he served as the logistics officer, to scout an area called the gravel plains located 30 kilometers northwest of qaraah. Krulak then directed Colonel Tace, his operations officer, to call Colonel Billy C. Steed, I MEF's operations officer, to find out when General Boomer would make his decision. Steed replied that Boomer would decide at the next commanders' meeting scheduled in less than 36 hours for 0830, 6 February.⁴⁰⁸ Early the next morning, McKissock led a small party to the gravel plains where they surveyed three locations. At each site, members of the team, which consisted of the DSC staff and a few battalion commanders, spent 30 minutes assessing the suitability of each location from their functional perspective. After returning to Kibrit, the team briefed General Krulak on the strengths and weaknesses of each site.⁴⁰⁹ The DSC commander selected a location to the east of the gravel plains, designated it as Combat Service Support Area 2 (CSSA-2), and after holding a quick "contest" among his staff to determine a suitable name, called it Khanjar after the dagger worn by Saudi males.⁴¹⁰

Of the three sites scouted by Colonel McKissock, Khanjar was the closest to the border, out of Iraqi artillery range, well positioned to support units attacking east into Kuwait, and flat and spacious enough to stage the huge amount of supplies needed to sustain the assault. Unlike Kibrit, the new location could not easily be supported from nearby Mishab, which required that the amount of supplies stored at Khanjar be doubled to 15 days. To make the rapid relocation, General Krulak needed Saudi Motors and all of his own transportation to stock Khanjar and to suspend unit distribution to DSG-1 and -2. In the event Boomer decided upon a two-division attack, Krulak ordered the DSC's earth-moving equipment loaded on trucks for rapid displacement to Khanjar.

Early the next morning, General Krulak drove 80 kilometers from Kibrit to I MEF's forward headquarters at Ras Al Safaniyah on the Persian Gulf. The



Photo courtesy of Col Alexander W. Powell

BGen Krulak briefs the DSC staff and commanders on 7 February 1991 at Kibrit. In the next two weeks, the DSC would relocate to a point three times the distance from the Port of Mishab and move more than twice the amount of supplies stocked at Kibrit. The relocation permitted I MEF to launch its attack into Kuwait on a two-division front.

commanders' conference started on time and addressed many subjects, some of which skirted the issue of the two-division breach. General Boomer encouraged maximum participation at his meeting and many commanders spoke about their portion of the upcoming battle. After three hours of discussion and no decision, General Krulak was concerned that time was wasting and that he needed to get his trucks on the road. Lieutenant General Boomer stopped the conference at 1130 for lunch and Krulak requested a few moments with the commanding general. He then briefed General Boomer that his trucks were ready to move to Khanjar, advised him that "every second counted," and asked the MEF commander whether a decision had been made. Boomer looked Krulak in the eye and said, "We will make a two-division breach of the Iraqi defenses..."^{411*} General Krulak's aide, First Lieutenant Joseph W. Collins, Jr., called Colonel McKissock at Kibrit who started the DSC trucks moving towards Khanjar and began I MEF's massive push to the west, less than 48 hours after General Krulak paid his courtesy call on General Keys.⁴¹²

Khanjar

At Khanjar, Lieutenant Colonel John's 7th Engineer Support Battalion took the lead in planning construction and worked as a team with Lieutenant Colonel Skipper's 8th Engineer Support Battalion. The two organizations raced to

*Gen Krulak commented that Gen Boomer's decision was very brave, since it would move I MEF's logistics another 100 kilometers in from the sea. Additionally, Gen Boomer made his decision to move to Khanjar over the objections of Col Raymond A. List, I MEF's logistics officer. (Krulak comments)

meet General Krulak's deadline of 20 February for establishing CSSA-2. While the two battalions swapped equipment as required, each worked on its own sets of projects which included building ammunition cells, berms, roads, working spaces, billeting areas, and setting up water and bulk fuel storage areas. Manning 12-hour shifts, the engineers operated the equipment 24 hours a day, except for that small amount requiring maintenance.* The Marines dug in a field hospital with 14 operating rooms and started a C-130 air strip, which became operational on the 10th. By the next week, the engineers had completed 24 miles of blastwall, 151 ammunition cells, 800 survivability positions, and huge water and fuel storage areas. The fuel farm dispensed fuel to ground vehicles and to MAG-26's new air facility at neighboring Lonesome Dove by pipeline.⁴¹³ The ammunition storage area, called Forward Ammunition Supply Point (FASP) 5, covered 770 acres while the entire Khanjar complex extended over 11,280 acres.^{414**}

The Seabees of NMCB-40 arrived at Khanjar on the 10th to drill for water. Unfortunately, after working around the clock and after reaching a depth of 1,050 feet, they still had discovered no water.⁴¹⁵ Four days after the Naval engineers started their drilling, Captain Peter M. Ramey, DSG-2's engineer detachment commander, noticed a metal pipe and a valve sticking out of the ground four kilometers northeast of Khanjar. When the Marines turned on the valve, water gushed out. General Krulak dubbed the discovery the "miracle well." The 8th Engineer Support Battalion sent a purification team which found that the water was of a terrible quality and dissolved the filters of their ROWPUs. Despite that problem, the engineers purified 100,000 gallons per day from the "miracle well," easing the burden for Marine motor transport units which had been hauling fresh water all the way from Mishab. By 19 February, the DSC had pooled a 796,000 gallon water reserve at Khanjar.⁴¹⁶

Lonesome Dove

At the same time as the DSC deployed to its forward base at Khanjar, the 3d MAW also established its supporting Lonesome Dove helicopter facility. Since 8 February, MAG-26 had stopped its move to Mishab and began its relocation to the new base next to Khanjar.^{***} Colonel Coop, the MWSSG commander, ordered Lieutenant Colonel Riznychok's MWSS-273 to deploy with the MAG. The MWSS immediately started shuttling engineer equipment from Mishab to Lonesome Dove on its three 870 trailers. To help with the relocation, Lieutenant

*After the battles of Khafji and OP-4, I MEF believed the Iraqis could not observe I MEF's movements and locations in Saudi Arabia. As a result, trucks drove along the Kibrit road using their headlights and engineer equipment operated at Khanjar with lights on. (Woodson and Songer intvw, 19Mar96)

**In March 1997, Gen Krulak remarked that Khanjar was so big that even six years after the war, you can still see its imprint on satellite pictures. (Krulak comments)

***Lonesome Dove was the name most commonly associated with the MAG-26 base. It was also called Khanjar and the Gravel Plains. Likewise, CSSA-2 at Khanjar was sometimes, if rarely, referred to as Lonesome Dove.

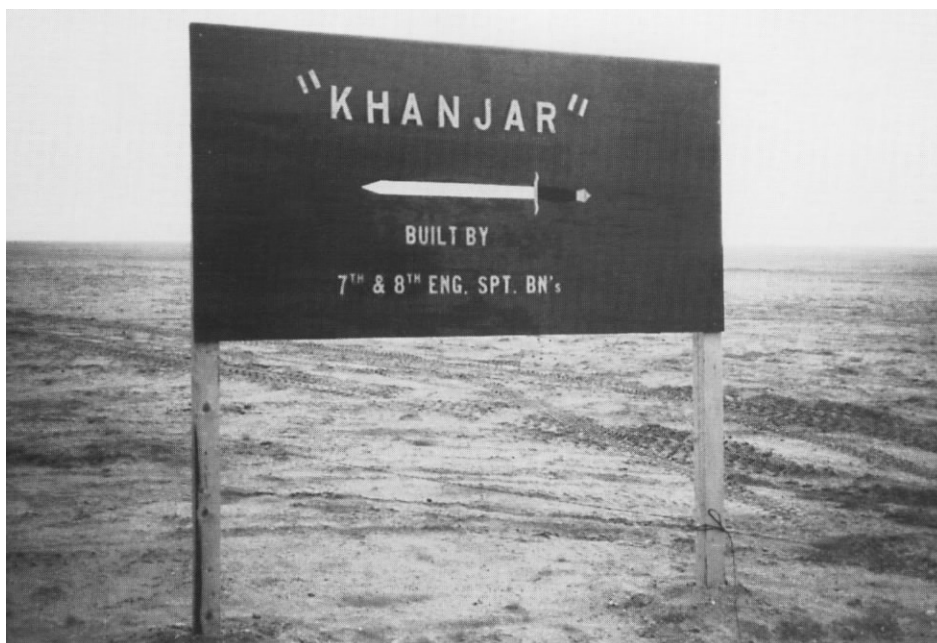

Photo courtesy of CWOS Thomas M. Sturtevant

The Marines named the new DSC support area "Khanjar," meaning "dagger" in Arabic. The 7th and 8th Engineer Support Battalions built this huge support base, whose outlines still can be seen clearly in satellite photographs six years after the war.

Hankinson's MWSSG-37 provisional truck company began moving AM2 matting, reinforcing 50 5-ton trucks already leant to the wing by the 1st Marine Division for the task.⁴¹⁷ Riznychok split his material handling equipment by assigning six forklifts to lay AM2 matting at the new location and kept the remainder of his equipment deployed between Mishab and Lonesome Dove. Having no trucks large enough to transport its giant rough-terrain container hauler (RTCH), MWSS-273 deployed to Lonesome Dove a 30-ton crane, which, while slow and somewhat inefficient, unloaded 140 ISO containers for MAG-26. Seabees from NMCB-24 joined MWSS-273's engineers and laid 900,000 feet of AM2 matting to park helicopters and surrounded the air field with a four-kilometer berm. DSC engineers set up an assault amphibious fuel system and connected it to MWSS-273's tactical fuel dispensing system. On the 19th, Colonel Coop sent MWSSG-37's nuclear, biological, and chemical team to MWSS-273 to establish a chemical casualty decontamination site. Three days later, with the help of commercial trucks, MAG-26 completed its move to Lonesome Dove.⁴¹⁸

The Seabees

To support the buildup and to conduct deception operations, Captain Johnson, the Seabee commander, sent additional elements of the 3d NCR to the border area. At Khanjar, NMCB-24, with the help of personnel from NMCB-5, erected I MEF's command post and, with the DSC engineers, built two airstrips,

one of which measured 6,600-feet by 150-feet and was completed in 48 hours. After about 20 landings, the Seabees graded and rolled each runway to keep them operational. To the southeast at Qaraah, NMCB-5 constructed a 1,500-foot runway with AM2 matting for remotely piloted vehicles, and maintained the airstrip for C-130 Hercules operations. From Kibrit, NMCB-74 participated in I MEF's deception effort. The Seabees built prefabricated tank turrets and artillery pieces from wood and moved them to an area along the Saudi-Kuwaiti border. The purpose of this operation, called Flail, was to trick the enemy into believing that I MEF's attack would be at a different time and location than planned. The Iraqis rewarded the Seabees' good work by shooting artillery and mortars at the decoys and maneuvering two brigades into the area.⁴¹⁹

The Buildup

The Marine motor transport units also had played an important role in the buildup of the new base areas. Since 9 February, the 8th Motor Transport Battalion, reinforced with trucks and drivers from the 6th and 7th Motor Transport

Diagram of CSSA-2 at Al Khanjar.

Diagram from DSC ComdC 22Dec90-15Feb91

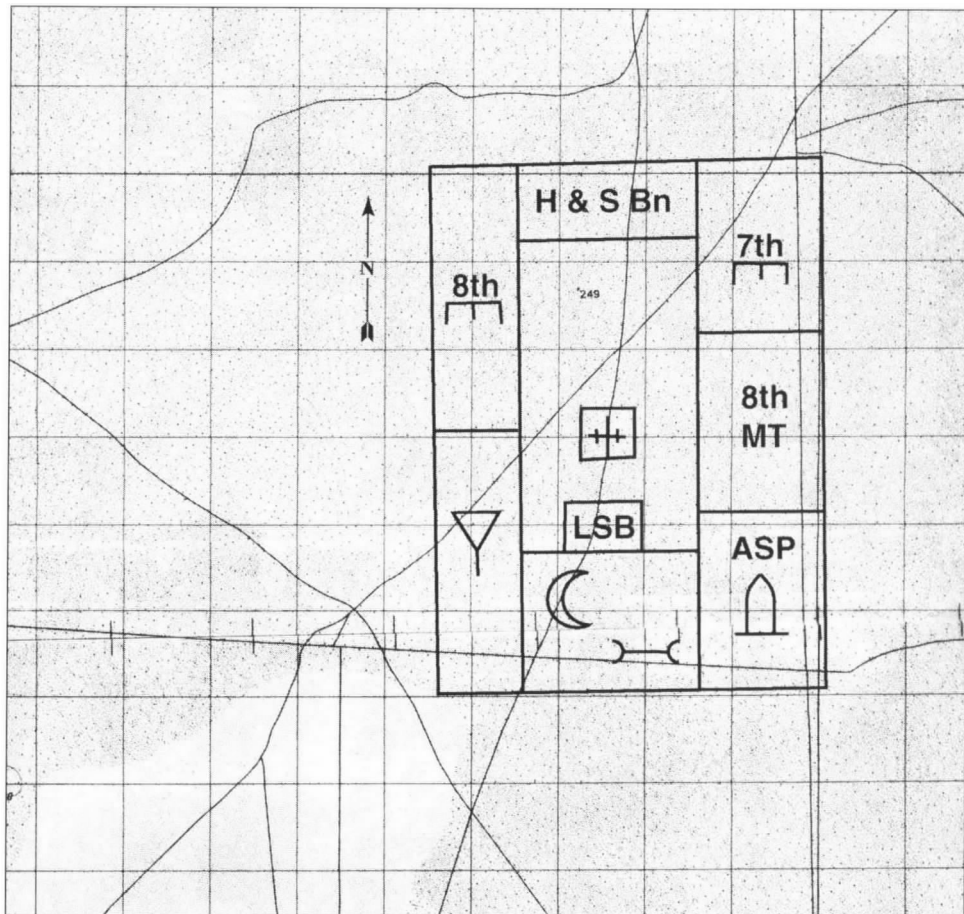



Photo courtesy of CWO5 Thomas M. Sturtevant

A DSC crane unloads an LVS with tandem trailers. The 8th Motor Transport Battalion, reinforced with elements of the 6th and 7th Motor Transport Battalions, drove 1.2 million miles in 14 days to stock Khanjar.

Battalions, suspended unit distribution to the DSGs and began moving supplies and equipment to Khanjar. Working around the clock and driving nights with lights on, the battalion moved containers, engineer equipment, repair parts, MREs, and medical supplies. Also working around the clock were the DSC's mechanics who kept 98 percent of the 8th Motor Transport Battalion's trucks on the road.⁴²⁰ Lieutenant Colonel Woodson, the battalion commander, concentrated the unit's efforts on emptying Kibrit and, after the 13th, redirected part of the battalion's assets to relocating the MEF headquarters to Khanjar, moving ammunition from Mishab, and picking up supplies from as far south as Jubayl.⁴²¹ During the 14-day push to stock CSSA-2, the 8th Motor Transport Battalion drove more than a million miles.^{422*}

While the DSC focused on moving from Kibrit to Khanjar, General Brabham relied on the 6th Motor Transport Battalion to push the additional eight days of supplies to CSSA-2. Lieutenant Colonel Walters used his Reserve drivers, the remaining foreign operators, and about 100 volunteers to establish a circuit course between Jubayl and FASP-5 near Khanjar. Walters called the FASP-5-Jubayl loop the Baghdad Express. Brabham contributed his personal driver, who along with the other volunteers, received a four-hour training package prior to making runs. Walter's plan called for establishing transfer points at Mishab and

*Six years after the war, Gen Krulak still stressed the accomplishments of the drivers from the 8th Motor Transport Battalion and their reinforcements from the 6th and 7th Motor Transport Battalions who drove the 1.2 million miles in 14 days. Additionally, he complimented the DSC's maintenance Marines who kept 98 percent of the trucks operational during the push to Khanjar. (Krulak comments)



Photo courtesy of CW05 Thomas M. Sturtevant

The "Baghdad Express" delivers a 40-foot container to the supply point at Khanjar. BGen Brabham sent I MEF its supplies on an assortment of civilian vehicles driven by Marine Reservists and third world nationals.

Khanjar where full trailers were exchanged for empty ones. Because of the incompatibility between the myriad types of civilian trucks and trailers and because many trailers were welded to their cabs, Walters ordered that rigs remain together for the entire trip. The 6th Motor Transport Battalion deployed three teams of drivers to work the Jubayl to Mishab, the Mishab to Khanjar, and the Khanjar to FASP-5 loops. At each location, the driver dropped off a full truck, picked up an empty rig, and returned to his point of origin to complete the loop and to start another.⁴²³

Almost immediately after the inauguration of the Baghdad Express, it ran into trouble with more than half of its 600 trucks breaking down on the road. General Brabham first concentrated his efforts on trying to fix the vehicles and ordered GSG-1 to repair as many trucks as possible. Major Felix M. Bush, the 2d Maintenance Battalion executive officer, lacked the mechanics, tools, and test equipment to repair major problems, but focused the efforts on ensuring that the hodgepodge of civilian trucks ran safely. Bush set up an assembly line in a warehouse at Jubayl to check, repair, and replace tires, brakes, brake lines, fuel lines, horns, and lights. The maintenance battalion requested bulk orders of parts through the GSG-1 staff, who coordinated purchases from the Saudi economy.*

*In addition to maintaining equipment, Col Marlin D. Hilton's 2d Maintenance Battalion conducted deception operations by intermittently moving and manning ORF tanks around the Port of Jubayl. On 16 February, a SCUD missile landed in the water 150 meters from Berth 6, which was packed with ammunition, and 300 meters from the USS *Tarawa*, which was carrying the 5th MEB. (Pankey comments; 1st FSSG ComdC Dec90-Feb91, Sec 3; GSG-1 ComdC Feb 91, Sec. 3)



Photo courtesy of LtGen James A. Brabham, Jr.
Marine mechanics from the 2d Maintenance Battalion at the Port of Jubayl repair one of the rickety commercial vehicles that made up the "Baghdad Express."

Farther north, GSG-2's maintenance detachment recovered and patched up some of the vehicles that broke down between Mishab and Kibrit, while the DSC's maintenance detachment recovered 283 vehicles between Kibrit and Khanjar.⁴²⁴

As the 2d Maintenance Battalion struggled to keep vehicles safely on the road, General Brabham threw more trucks at the problem. Brabham ordered his supply support officer, Major Philip N. Yff (pronounced eyeff), who spoke Arabic and knew the region's customs, to concentrate his efforts on obtaining more trucks from the Saudi economy.* This was not an easy task since competition was fierce among the Marine Corps, the U.S. Army, the British, and the Saudi military

*Maj Yff accompanied Gen Brabham to Saudi Arabia in August 1990. (Kelly comments)



Photo courtesy of LtGen James A. Brabham, Jr.

The DSC engineers built 151 ammunition cells at Khanjar FASP-5. These cells held more than 40,000 tons of munitions, enough for 15 days of combat for the 1st and 2d Marine Divisions.

to obtain local transportation. Yff travelled throughout Saudi Arabia and the neighboring country of Qatar hunting for vehicles. Choking down large quantities of tea and coffee, both of which he disliked, and sitting patiently through long meetings with Arab vendors, Yff successfully bargained with local businessmen and procured 500 vehicles to support the buildup.⁴²⁵

At Mishab, GSG-2's 7th Motor Transport Battalion pressed into service a rickety collection of contracted trucks to push water to Khanjar. Major Yff sent Lieutenant Colonel Smith, the battalion commander, 46 commercial tractors and 40-foot trailers fitted with sixcon water pods. Reserve Marines from the 4th Landing Support Battalion received only one hour of instruction at Jubayl prior to operating the 16-speed, split-shift manual transmissions of the water trucks. Almost immediately, broken-down water trucks littered the road as a result of burned-out clutches, bad road conditions, and the overall poor condition of the vehicles. To compensate, Major Yff scrapped the bottom of the barrel and sent 65 more commercial water trucks. Of the vehicles that limped into Mishab on bald tires and wheezing engines, only 40 percent were sanitary enough to transport potable water. Major Robert W. Ferguson, Jr., the 7th Motor Transport Battalion's operations officer, was certain that the Saudis had robbed every junk yard in the Persian Gulf, and the battalion's maintenance detachment succeeded in keeping only a discouraging number of the derelict fleet on the road with spare parts purchased from the local economy.⁴²⁶

To stock Khanjar with 15 days of fuel, GSG-2's 7th Motor Transport Battalion put its 25 refueling vehicles, which were mostly M970 5,000-gallon



Photo courtesy of LtGen James A. Brabham, Jr.

A C-130 Hercules cargo aircraft lands on the dirt strip at Khanjar. Both USMC and USAF aircraft flew cargo an average of 25 missions each day to Khanjar, Qaraah, and Kibrit.

refuellers, on the road. Lieutenant Colonel Smith, however, did not have enough trucks to haul the required amount of fuel. To help, I MEF acquired the services of 60 M967 5,000-gallon bulk hull refuellers from the U.S. Army, which were operated by the Army's 10th Transportation Battalion, and the 475th Quartermasters Group (240th and 370th Quartermaster Battalions).⁴²⁷ The Army trucks moved fuel in large convoys that stretched over the horizon. The DSC's bulk fuel Marines, knowing that they were in for a work surge when the Army rolled into Khanjar, called the convoys the "trucks from hell."^{428*} Between the Army and GSG-2, Khanjar's stocks reached 4,800,000 gallons of fuel by 19 February.⁴²⁹

General Brabham also pressed into service 3d MAW helicopters, Army coastal craft, and U.S. Air Force C-130 aircraft to push supplies north. Working from the concept that every little bit helps, the 3d MAW flew an average of 25 missions a day moving cargo to Khanjar, Kibrit, and Qaraah. Responding to a request from I MEF's Military Airlift Command's liaison officer, the Air Force flew an average 50 C-130 sorties a day to I MEF's expeditionary airfields at Mishab, Kibrit, Qaraah, and Khanjar. General Brabham obtained the use of logistics support vessels and landing craft from the U.S. Army which made the run from Jubayl to Mishab. At Mishab, GSG-2 unloaded two more ships during the month and sent the contents to Khanjar and Lonesome Dove.⁴³⁰ On the 17th, Colonel Hampton, the GSG-2 commander, ordered the 2d Landing Support Battalion, under Lieutenant Colonel David B. Kirkwood, to redesignate as CSSD-82 and to operate Kibrit after the DSC moved to Khanjar. The same day, General Brabham transferred CSSD-133 at Tanajib to GSG-2.⁴³¹

The roads between Mishab and Khanjar at some points exceeded fourteen

*On one day during the buildup, the 240th Quartermaster Battalion hauled 495,000 gallons of fuel to Khanjar. (Skipper comments)

rutted lanes in width and required extensive maintenance. Captain Johnson, the Seabee commander, ordered NMCB-74 at Kibrit to maintain the 100 kilometers of road between Mishab and the intersection of the Qaraah road. NMCB-5 and elements of NMCB-40 at Qaraah were responsible for the road from Qaraah to the intersection of the Kibrit highway and from there west to the Khanjar road. Johnson gave NMCB-24 the responsibility for the last leg of the main supply route from Khanjar to the intersection with the Kibrit road. He pulled people and equipment from Bahrain and sent them north to augment the road maintenance effort.⁴³²

The 2d Marine Division and DSG-2 Move West

DSC's move to Khanjar allowed the 2d Marine Division to plan a separate breach of the Iraqi defenses northwest of the 1st Marine Division. I MEF's new scheme of maneuver shortened and modified the direction of the 2d Marine Division's attack route without changing either division's objectives. To execute the new plan, the 2d Marine Division would attack from positions between Khanjar and the border with the 6th Marines given the mission to lead the way into Kuwait through the Iraqi minefield, followed by the Tiger Brigade and 8th Marines.⁴³³ After crossing both obstacle belts, the Tiger Brigade would swing to the left of the 6th Marines and the 8th Marines would maneuver to the east. The 2d Tank Battalion would remain in reserve.

In preparation for its new mission, the 6th Marines had deployed, on 6 and 7 February, to a breach-training area located 30 kilometers west of Kibrit to practice piercing the Iraqi minefields. Colonel Livingston, the regimental commander, planned to cut six lanes through the two Iraqi obstacle belts with Task Force Breach A and Company C, 2d Combat Engineers.* On the 11th, the DSC sent Captain Brian J. Hearnberger's Company B, 8th Engineer Support Battalion, to the 2d Marine Division to reinforce the 6th Marines breaching effort.⁴³⁴ Following the engineers, the 1st Battalion, 6th Marines; the 2d Battalion, 2d Marines; and the 1st Battalion, 8th Marines, all mechanized, would cross the obstacle belts on two lanes each and establish a breachhead on the far side of the minefields. The 8th Tank Battalion; the 3d Battalion, 6th Marines (motorized); the 2d Battalion, 10th Marines, and MCSSD-26 would move behind the mechanized battalions. After the 2d Battalion, 10th Marines, established firing positions on the far side of the minefields, the 2d Battalion, 12th Marines would move through the breach and join the regiment.⁴³⁵

Since 8 February when it had arrived at the breach training area and established RRP Moats there, MCSSD-26 supported the 6th Marines, pulled supplies from Kibrit, expanded its medical capability, and rehearsed its role in the

*Company C, 2d CEB, was a remnant of Task Force Breach B which was formed to support the 8th Marines in January 1991. After 5 February, Task Force Breach B ceased to exist and Company C, reinforced with tanks and AAVs, was placed in direct support of the 1st Battalion 8th Marines. (2d CEB ComdC 16Jan-28Feb91, Sec II)

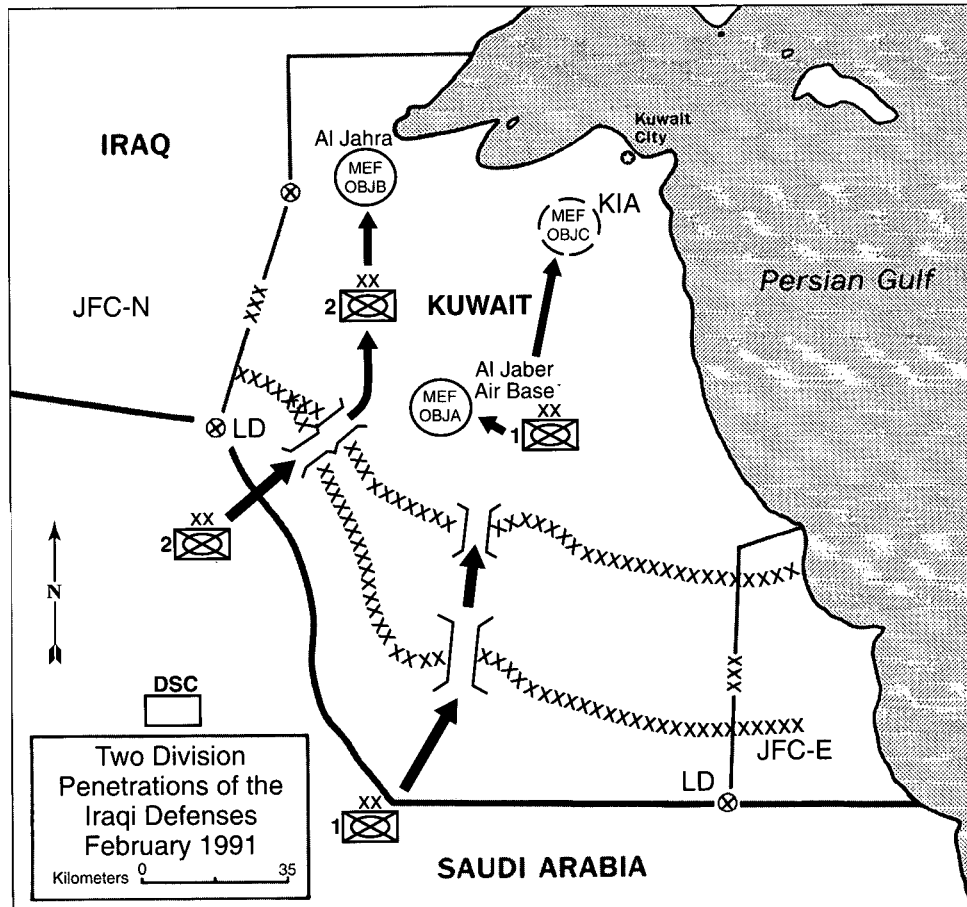

assault. The breach training area was laid out with six lanes on the same azimuth and scale that the 6th Marines would face in Kuwait.* For several days, the mobile, under Lieutenant Colonel Wittle, practiced and simulated different problems that could arise in the minefields, such as blocked lanes and radio jamming. Wittle would move MCSSD-26 in two serials as a component of the 6th Marines team, which reached a size of 7,800 Marines and sailors and 1,098 pieces of rolling stock.⁴³⁶ The large force drilled moving rapidly through the simulated obstacle belts to avoid bunching up and becoming lucrative artillery targets.^{437**} After training during the day, each night MCSSD-26 distributed to the regiment an average 15,000 gallons of water, 36 pallets of MREs, and 16,000 gallons of fuel. Adding to the exhaustive schedule, Lieutenant Colonel Wittle sent convoys to Kibrit to pull supplies for the regiment. Also at RRP Moats, a 20-man collection and clearing team, led by Navy Lieutenant Kenneth P. Collington, joined the

*In accordance with doctrine, the engineers marked the lanes with trash cans painted red for lanes 1 and 2, blue for lanes 3 and 4, and green for lanes 5 and 6. (Skipper comments)

**During this period, Hearnberger's Company B, 8th Engineer Support Battalion, worked closely with the 6th Marines to identify and practice command and control procedures similar to those used in an amphibious landing. (Skipper comments)

MCSSD, giving it the ability to stabilize, resuscitate, and evacuate casualties.⁴³⁸ The 6th Marines called the arrival of the collection and clearing team a “major milestone” and “the final facet of the regimental ground evacuation plan . . .”⁴³⁹

In the meantime, Colonel Schmidt had moved his 8th Marines into the 6th Marines’ old defensive positions south of Al-Wafra, transferred the 1st Battalion, 8th Marines, to the latter regiment, and added the 2d Light Armored Infantry Battalion and the 2d Reconnaissance Battalion to his operational control.* Moving in two echelons, MCSSD-28, under Lieutenant Colonel James W. Head, joined the 8th Marines and established a position 25 kilometers south of the border and 40 kilometers northwest of Kibrit. At this location, the mobile again pushed support to the regiment’s battalions while Captain Drew B. Miller, the assistant operations officer, refined the mobile’s extensive biological and chemical defensive capabilities and procedures.⁴⁴⁰ Five days after arriving, a fire broke out on 13 February, destroying a MCSSD-28 refueler during a resupply mission with Company F, 2d Light Armored Infantry Battalion. While northwest of Kibrit, MCSSD-28 added a collecting and clearing and graves registration team to its roster bringing the personnel strength of the mobile to 241.⁴⁴¹

Until the 16th, DSG-2 remained at Hobo Alley where it prepared to move to the northwest in accordance with the DSC’s deployment plan. A week earlier, after reviewing stockage levels and lift requirements, the DSC had suspended unit distribution to permit DSG-2 and its mobiles to relocate to the northwest using their own transportation. Upon completion of the relocation, the DSC would reinstate unit distribution and replenish DSG-2’s stocks.⁴⁴² Accordingly, DSG-2 remained south of the Kibrit road, topped off passing 2d Marine Division units who then drew their supplies from the DSC as they moved farther west.^{443**} For example, MCSSD-26, which pulled supplies from Kibrit, supported the two artillery battalions in direct support of the 6th Marines.⁴⁴⁴ Additionally, the 502d Support Battalion, which supported the Tiger Brigade, pulled supplies from the Marines with 80 fuel and cargo trucks and some commercial water tankers that it had received from ArCent.⁴⁴⁵ To supply the Tigers with rocket pods for their Multiple Launch Rocket Systems (MLRS), Captain Tobin, DSG-2’s liaison officer to the 502d Support Battalion, coordinated delivery of 60 MLRS pods with the 8th Motor Transport Battalion.^{446***}

Finally, on the 14th, MCSSD-26 led the way west for DSG-2 by establishing RRP Stewart, 20 kilometers northeast of Khanjar and 22 kilometers from

*The lack of trucks caused the 8th Marines to take four days to deploy its two remaining battalions to the Kuwaiti border. MCSSD-28 provided truck support to the regiment. (Head comments)

**The units that topped off at Hobo Alley drew down DSG-2’s stock of supplies and reduced the burden of its pending move west. (Donnelly comments)

***Because of the size of the MLRS pods, the 8th Motor Transport Battalion dedicated 15 LVSs with tandem trailer to make two round trips from the FASP-4 at Kibrit to the Tigers’ location. Col Woodson considered the large but light MLRS pods, which required one LVS bed to haul each pod, inefficient but necessary loads. (Woodson and Songer intvw, 19Mar96)

the border. Two days later, the 6th Marines moved to its final assembly areas northeast of Khanjar and within 10 kilometers of the Kuwaiti border.⁴⁴⁷ Colonel Livingston deployed his assault battalions on a 20-kilometer north-south line which protected his reserve battalions, the artillery, Task Force Breach A, and MCSSD-26. The mobile was located 13 kilometers from the most distant element of the regiment.⁴⁴⁸ At that time, Colonel Donnelly moved DSG-2 to a position behind the 6th Marines, which was 15 kilometers northeast of Khanjar, 15 kilometers southwest of the border, and 7 kilometers from the 2d Marine Division Command Post.⁴⁴⁹ DSG-2's new combat service support area became known as the Ponderosa.^{450*} On 19 February, the 8th Marines moved to its final preattack positions, 10-15 kilometers southwest of the Kuwaiti border. Lieutenant Colonel Head moved MCSSD-28 to a new location to support the 8th Marines. The mobile was located 6 kilometers southwest of the regimental headquarters, 7 kilometers south of the Ponderosa, and 10 kilometers east of Khanjar.⁴⁵¹

*Pushing Forward to the Ground War: Final Plans,
Preparations, Problems, and Positions*

*At the end of those [last] two weeks we had 15 days of supply at Khanjar, three days with each of the direct support groups, and a day with each of the mobile combat service support detachments—in addition to whatever the divisions were carrying themselves.*⁴⁵²

The Direct Support Command

The logistics “center of gravity” for I MEF’s imminent ground attack was Khanjar, which reached General Krulak’s stockage goal of 15 days supply on 20 February. From Khanjar, Krulak planned and then pushed supplies and capabilities as far forward as possible to give the divisions every advantage to defeat the enemy. To replenish each of the artillery regiments with the divisions, the DSC and DSG-1 planned to deliver ammunition for the preparatory fires and for the assault at the first obstacle belt. To sustain the attack, every firing battery in I MEF would advance into Kuwait accompanied by ammunition trucks from the DSC and both DSGs. After crossing the first obstacle belt, the DSGs would drop the ammunition between the belts to be used in the artillery bombardment on the second line of obstacles. The DSC’s trucks would move with the artillery to the far side of the second barrier line to support subsequent operations. When the DSC trucks returned, General Krulak planned a transfer point at Al Jaber Air Field, MEF Objective 1, to facilitate the capture of MEF Objectives 2 and 3.⁴⁵³ For

*Col Donnelly commented that pilots named DSG-2’s combat service support area “the Ponderosa.” The Ponderosa was the ranch in the popular 1960s western television show “Bonanza.” According to Col Donnelly, “I was told that during air briefings, because the circular shape of DSG-2’s position resembled an enormous wagon wheel, the DSG-2 position became a recognized vector for pilots. Consequently, pilots began referring to the DSG-2 site as the Ponderosa.” (Donnelly comments)

emergency situations, the DSC's landing support detachment pre-staged MREs, fuel, and 40 ammunition supply blocks for rapid helicopter resupply.⁴⁵⁴

Table: The artillery ammunition support plan

Event	Mode of Supply	Responsible for Delivery to 10th Marines	Responsible for Delivery to 11th Marines
Preparatory Fires/ Assault on 1st Obstacle Belt	Pre-G-Day Lay-Down	DSC	DSC/DSG-1
Assault on 2d Obstacle Belt	Mobile Load	DSG-2	DSG-1
Targets Immediately Beyond the 2d Belt	Mobile Load	DSC	DSC
Subsequent Targets	Mobile Load	10th Marines	11th Marines

With the build up at Khanjar almost finished, the DSC turned to stocking CSSD-10 and DSG-2 with three days of water, MREs, fuel, lubricants, and two days of ammunition.⁴⁵⁵ From the 18th to the 23d, the 8th Motor Transport Battalion hauled to DSG-2's dumps at the Ponderosa more than 180,000 gallons of fuel, 60,000 gallons of water, 43 LVS beds of ammunition, 74 pallets of MREs, 75 pallets of general cargo, two LVS beds of medical supplies, and two 5-ton truckloads of blankets for enemy prisoners of war.^{456*} At the same time, the transport battalion brought in over 216,000 gallons of fuel, 102 LVS beds of ammunition, 83 pallets of packaged oils and batteries, 78 pallets of medical supplies, and 5 pallets of repair parts to create the necessary supply stocks at CSSDs -10 and -13.⁴⁵⁷

General Krulak placed both of his engineer support battalions forward with the divisions for the attack. He ordered the 7th Engineer Support Battalion to help the 1st Marine Division while the 8th supported the 2d Division. After completing Khanjar, both engineer support battalions also assisted the two DSGs by building ammunition supply points and blast berms at their new positions. To support the initial attack and to later supply the MEF in Kuwait, Captain William Hatton's Company A, 8th Engineer Support Battalion, manned mostly by Reserves, completed a 35-kilometer, four-lane road, known as the Khanjar

*"Bed" was a measurement term commonly used to denote a trailer load of cargo. The use of LVSs to haul tandem trailers strengthened the use of the word "bed," as opposed to "truck load," since one prime mover or truck could haul two trailers or "beds." (Woodson and Songer intvw, 19Mar96)

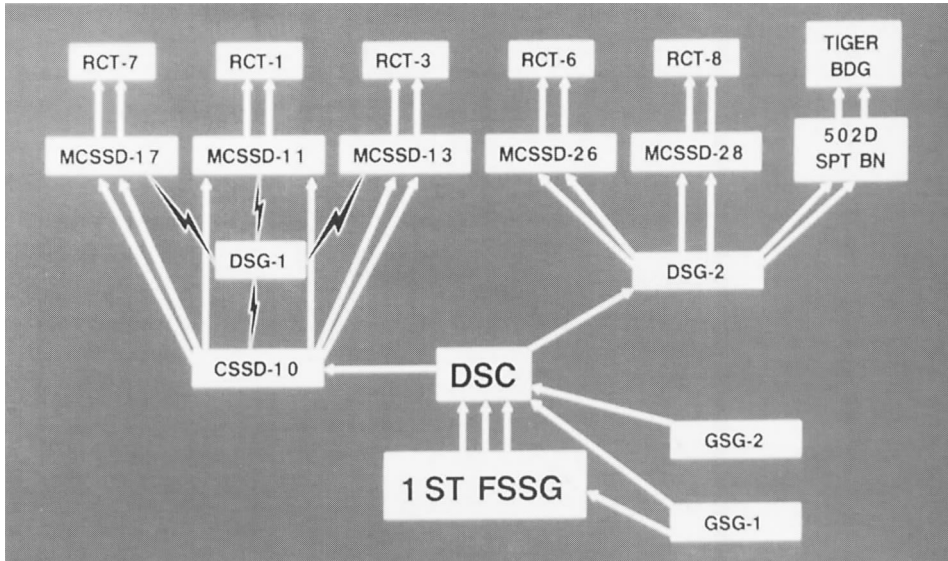

Photo courtesy of LtGen James A. Brabham, Jr.

A briefing slide explains the 1st FSSG distribution system in the Persian Gulf.

Expressway, from Khanjar to the Saudi berm. The three- to four-meter high berm ran parallel to the border on the Saudi side and served as a point of reference as well as an obstacle to be crossed.* On 21 February, the 7th Engineer Support Battalion began slicing through the Saudi berm and the next day, dug in the 11th Marines' artillery while under fire.⁴⁵⁸ Also on the 21st, Captain Hearnberger led his Company B, 8th Engineer Support Battalion, which had been assigned to the 2d Marine Division since early February, to the Saudi berm in front of the Tiger Brigade. Hearnberger's engineers punched nine 50-meter-wide holes in the berm to confuse the enemy about the location of the 6th Marines attack.^{459**}

Direct Support Group 2

On 21 February, Colonel Donnelly briefed DSG-2's concept of support to General Keys, who approved the plan.^{***} The DSG planned to top off the 2d Marine Division with water and fuel prior to the assault, send artillery ammuni-

*The Saudi berm was "built by the Japanese for the Saudi government...it was made by bulldozing the desert sand into a continuous wall, attaining a height of three to four meters in places. It followed the Saudi-Kuwaiti border from between 1-5 kilometers on the Saudi side and was visible from 10 kilometers away. The berm provided excellent concealment to forces just behind it, and a good vantage point from which to observe Kuwait." (2dMarDiv ComdC, 1Jan-13Apr91, Sec 2)

**To deceive the Iraqis on the location of the 2d Marine Division attack, engineers cut 18 holes through the berm between 20 and 22 February. Only the six slots in front of the 6th Marines were intended for use. (Cureton, *With the 2dMarDiv*, p. 38)

***DSG-2's staff briefed the concept of operations to BGens Krulak and Russell H. Sutton, the Assistant Division Commander of the 2d Marine Division, on 23 February. (Donnelly comments)



Photo courtesy of Maj Adrian W. Burke

Capt Adrian W. Burke and a small reconnaissance party look through high-powered binoculars at Iraqi-held Kuwait from the Saudi berm. Japanese engineers built the three- and four-meter-high berm just inside Saudi Arabia and parallel to the Kuwaiti border. The Marines used the berm for observation, concealment, and as a point of reference.

tion to the 10th Marines, establish a forward medical capability, and project transfer points in Kuwait. As the 2d Marine Division moved to the attack, Donnelly intended to establish RRP's at each of the three breach assembly areas so that attacking units could obtain water and fuel. He designated Captain Matter, DSG-2's motor transport officer, to establish the RRP's on 22 February. To medevac wounded after the assault on the breaches, Colonel Donnelly aimed to locate a collection and clearing station, under First Lieutenant Antonio Colmenares, DSG-2's assistant operations officer, inside Kuwait near the first line of obstacles, and on the 23d, ordered the lieutenant to stage his new command south of the Saudi berm.^{460*} To support the artillery, the DSC loaded 20 LVSs with artillery ammunition to travel through the breaches with the 10th Marines. In addition, Donnelly sent five LVSs with munitions and repair parts to support the Tiger Brigade. The DSG-2 commander assigned his remaining 10 LVSs to Lieutenant Colonel Hering, the DSG's executive officer, and directed him to establish a transfer point north of the second breach and later south of MEF Objective B at Al Jahra. The transfer points would distribute fuel, water, and MREs and provide maintenance and ground medical evacuation of casualties.** On the 23d, Hering had his convoy inside the Ponderosa ready to move out.⁴⁶¹

As did his fellow commanders in the 6th Marines, Lieutenant Colonel

*Col Donnelly commented that "Casualties were to move to the rear by lifts of opportunity. This guidance came from both the DSC and the division's assumptions. It seemed prudent to establish a medical collection point as close to the breach as possible . . ." (Donnelly comments)

**Col Donnelly added that, "No resupply or forward movement from DSG-2 was envisioned for the first 18 hours." (Donnelly comments)

Wittle used the last days before the attack to prepare his unit for war. MCSSD-26 loaded one day of ammunition; 25,000 gallons of fuel; 20,000 gallons of water, of which 6,000 was non-potable to be used for decontamination purposes; batteries; packaged oils and greases; medical supplies; and 16 pallets of MREs. M870 heavy equipment trailers pulled by LVSs carried the D-7 bulldozer and 10-ton Terex forklift, while smaller forklifts and the 7-1/2 ton crane followed behind the trucks under their own power. To recover vehicles and to medevac people, the mobile had an M936 wrecker, M88A1 tank retriever, assault amphibious vehicle retriever, an LVS 48/15 wrecker, and six HMMWV ambulances. MCSSD-26 also carried collection and clearing, helicopter support, maintenance contact, and the newly joined graves registration teams. The latter capability consisted of 12 personnel led by Sergeant John M. Kananowicz.⁴⁶² Lieutenant Colonel Wittle divided MCSSD-26 into two serials consisting of 35 vehicles each, and placed Major Clarke, the executive officer, in charge of the second serial while he stayed with the first.⁴⁶³

The 6th Marines, like all Marine Corps ground combat elements, carried a significant array of combat service support capabilities. Prior to the assault, MCSSD-26 pushed two-days' ammunition, water, fuel, and MREs to the battalions of the 6th Marines. Between the 16th and 23d of February, MCSSD-26 pushed 12,000 gallons of water, 44 pallets of MREs, and 12,000 gallons of fuel daily to the regiment.⁴⁶⁴

MCSSD-26 had distributed these commodities to their companies or carried them in the battalion logistic trains. For example, the 1st Battalion, 6th

The officers and noncommissioned officers of MCSSD-26 pose for their picture on 23 February. LtCol Wittle, the commanding officer, is in the middle of the front row. Moving to the right are Maj Charles Clarke, executive officer, and Capt Peter W. Warker, operations officer. Also pictured are members of a civil affairs group who arrived in time to have their picture taken before moving on to another location.

Photo courtesy of Maj Peter W. Warker



Marines (mechanized), after distributing general supplies and one-day ammunition supply to its companies, hauled two-days' worth of MREs, 1,600 gallons of water, 16,232 gallons of fuel, and one-day's ammunition in its 42-vehicle train. In addition to basic supplies, the battalion took with it a cache of repair parts and an aid station. The infantrymen converted two amphibious assault vehicles into ambulances to evacuate the wounded who would be carried to the ambulances on stretchers by the cooks. The cooks also served in decontamination teams and provided additional security. MCSSD-26 delivered supplies directly to the battalion logistic convoy which moved 500-1000 meters behind the unit's command element.⁴⁶⁵

Located 18 kilometers southwest of the border, Lieutenant Colonel Head's MCSSD-28 loaded trucks to support the 8th Marines who would follow the 6th Marines and the Tiger Brigade into Kuwait on the second day of the war. MCSSD-28 carried 40 pallets of MREs; 10,800 gallons of potable water; 6,000 gallons of non-potable water for decontamination; 19,500 gallons of fuel, packaged lubricants and oils; and one-day's worth of ammunition. Like MCSSD-26, MCSSD-28 provided on-call helicopter support, collecting and clearing, maintenance, vehicle recovery, and graves registration support. Unlike MCSSD-26, MCSSD-28 did not have a TOW section for protection, but planned to travel with the regimental logistics train and to carry 100 infantrymen from the 8th Marines. This arrangement strengthened MCSSD-28's defenses, which consisted of machine guns, Mk 19 grenade launchers, and AT-4 anti-tank systems. On the 23d, Lieutenant Colonel Head lined-up MCSSD-28 for the attack into Kuwait.⁴⁶⁶

Direct Support Group 1

After moving Task Force Taro to Qaraah on 16 February, General Myatt completed his plan of attack.⁴⁶⁷ Myatt ordered Task Force Ripper, responsible for the division's main effort, to attack towards Al Jaber Air Base and Task Force Papa Bear to assault on Ripper's right flank. The 4th Marines, now called Task Force Grizzly, and Task Force Taro were to infiltrate the first line of obstacles on the division's flanks prior to G-day. The foot-mobile Grizzly and Taro would guard the 11th Marines as it moved into Kuwait to fire in support of the infantry while Grizzly and Taro protected Ripper and Papa Bear's flanks. The change to Taro's mission caused Colonel Powell, the DSG-1 commander, to modify CSSD-13's role from direct support of Taro to general helicopter-resupply support of the division. Powell ordered Captain Ritchie to focus on resupplying Taro, Grizzly, and Shepherd.

Not deterred by the additional burden of supplying two more task forces, Captain Ritchie found that CSSD-13's experience with Taro prepared his command for its larger mission. The support packages, which CSSD-13 organized for Taro, were usable by Grizzly and Shepherd. CSSD-13 made a list of the resupply packages, assigned brevity codes, and circulated the list within the division and DSG-1. The use of brevity codes allowed units to call quickly for helicopter resupply and minimize radio traffic over the shaky communications system. For

example, if Task Force Grizzly wanted a day's worth of ammunition for an infantry company (Brevity Code - "Shark") it would send the following brief message—"CSSD-13, "Shark" at Grid 12345678." To enhance communication, Captain Ritchie sent liaison officers to establish radio contact with Task Forces Grizzly, Taro, and Shepherd. He then analyzed the division's scheme of maneuver, while Captain Kenneth M. Brown, the CSSD's operations officer, scheduled daily resupply missions with the 3d MAW's helicopter squadrons. Colonel Powell assisted Captain Ritchie by sending all available landing support equipment to CSSD-13. To back-up the CSSD in case of limited helicopter support, Colonel Powell directed MCSSDs -11 and -17 to be prepared for on-order missions to support the infantry task forces.⁴⁶⁸

Besides the last-minute adjustment of missions, ammunition planning remained a lingering problem within DSG-1. The large amount of artillery ammunition required by the 11th Marines and the uncertainty surrounding the daily allowances of non-artillery munitions were major concerns. Major Lucenta, CSSD-10's operations officer, calculated that it took 88 LVS-loads to haul one-day's worth of artillery ammunition for the regiment. This caused complications since CSSD-10 had only 70 LVSs and seven 5-ton trucks to move ammunition to the 11th Marines, resupply MCSSDs -11 and -17, and to relocate itself. The CSSD simply did not have enough vehicles to do the job easily.⁴⁶⁹ The second hurdle involved ammunition allowances. Division units requested amounts of ammunition that exceeded those allowed by a 1985 Marine Corps order, which resulted in the I MEF ammunition officer disapproving the requests.* Frustrated that a six-year-old Marine Corps order was viewed as more accurate than their judgment, the 1st Division logistic officers continued to resubmit their requests which were duly disapproved. DSG-1's load planners were caught between the division and the MEF, since they had to draw and deliver the division's ammunition, no matter what amount was approved. Finally, the MEF ammunition officer declared all division calculations invalid and together with the division's ammunition officer computed a new set of allowances which went into effect on 16 February. Unsatisfied, task force ammunition planners continued to submit requests for additional allotments.⁴⁷⁰

The major burden of DSG-1's pre-G-day preparations and its post-G-day ability to support extended operations, fell on CSSD-10. To execute his mission, Lieutenant Colonel Kelly planned to move CSSD-10 near the border to OP-4, four days prior to the attack. From the new position, he would build up three-days' supplies, set up a collecting and clearing company to treat casualties resulting from the attack on the first obstacle belt, and establish a decontamination site. From OP-4, the CSSD would send five ammunition trucks to each battery of the 11th Marines to support the division's assault on the second belt. Lieutenant Colonels Kelly and Leonard M. Supko, the 11th Marines' logistics officer, spent a good deal of time coordinating the artillery ammunition plan which would tie up most of CSSD-10's trucks for the first day of the war.

*Marine Corps Order 8010.1D, Class V (W) Supply Rates for Fleet Marine Force Combat Operations.



Photo courtesy of Maj Adrian W. Burke

In the field, MCSSD-11 Marines "lived like Grasshoppers." in an environment providing nothing but sand and air to work with. Everything needed to fight and survive had to be carried by the forces deployed. This reality remained throughout the conflict.

To support subsequent operations, Lieutenant Colonel Kelly planned to move elements of CSSD-10 into Kuwait. Kelly organized a "medical mobile" consisting of six M997 HMMWV, two busses configured by GSG-1 as ambulances, a shock/trauma platoon, a chaplain, and a security element, to evacuate the high number of casualties expected to occur at the second obstacle belt. Ensign William C. Hancock, the executive officer of Collecting and Clearing Company A, led the medical mobile. Because most of its trucks were hauling artillery ammunition, CSSD-10 would not be able to resupply MCSSDs -11 and -17 until the second day of the war. After retrieving the ammunition trucks and resupplying the MCSSDs, Kelly intended to move north of the second obstacle belt. Expecting heavy casualties from the fight at the Al Jaber Air Base, CSSD-10 planned to set up a collecting and clearing company to treat the wounded.⁴⁷¹ To sustain the final attack on Kuwait International Airport, Kelly aimed to move to a position 15 kilometers southwest of it. Even with the plan in place, Kelly spent 80 percent of his time wrestling with ammunition resupply and casualty evacuation matters.⁴⁷²

Colonel Powell, the DSG-1 commander, continued to meet and brief General Myatt and his staff to ensure that the division's logistics priorities were met and that required trade-offs were understood and accepted. In consonance with Myatt's priorities, Powell designated Task Force Ripper as DSG-1's main focus for combat service support. The DSG commander used consumption data compiled during the previous months to convince General Myatt and his commanders to reduce the amount of fuel, water, and MREs carried by MCSSDs -11 and -17.* These cuts saved space on trucks which were used to transport more ammunition and to increase DSG-1's ground medevac capabilities.⁴⁷³ For pur-

*MCSSD -11 and -17 dropped the amount of water carried per man per day to 1.5 gallons from 6 and decreased the number of MREs per man per day to one from three. DSG-1 used a planning factor of 60,000 gallons of fuel per day instead of the division's estimate of 120,000.

poses of efficiency, CSSD-10 reduced from 35 LVS bed loads to 17 the amount of equipment deployed by a collecting and clearing company.⁴⁷⁴ To save space, DSG-1 dispensed with most of its unit equipment, and, according to Captain Jeffrey J. Morsch, DSG-1's historian, "lived like grasshoppers out there in the sand." Throughout the planning process, Colonel Powell continued to update and obtain General Myatt's understanding and concurrence of his plans. On 20 February, during an extensive sand table exercise, Powell, together with the division's other task force commanders, briefed his final plan of action to Myatt and his staff.⁴⁷⁵

In addition to dealing with his customers, Colonel Powell spent a good portion of his time keeping General Krulak and the DSC staff informed of his intentions. Powell visited the DSC at Kibrit and at Khanjar about five times a week, attended meetings, and kept the DSC current on his plans, activities, and problems. General Krulak enhanced communication by his numerous visits to the DSG headquarters and to the CSSDs and MCSSDs. As early as 7 February, Colonel Powell and his commanders presented their general support plan to General Krulak and received his approval. Throughout the remainder of the month, Powell kept the commanding general aware of such items as the modification to CSSD-13's mission. An unresolved chronic issue remained — the shortage of equipment, especially trucks, Position Locating and Reporting Systems (PLRS), Global Prepositioning Systems (GPS), night vision goggles, and anti-tank weapons. Powell pressed the issue with Krulak, who guaranteed that he would push additional equipment to DSG-1 after the DSC set up at Khanjar.⁴⁷⁶

During the last days before the ground attack, General Krulak made good on his promise and forwarded equipment and supplies. DSC gave DSG-1 10 LVSs and trailers; 5 M970 5,000-gallon refuellers; 10 Mercedes Benz water tankers, which provided CSSD-10 the ability to carry 66,000 gallons of water at one time; and materials-handling equipment to quadruple CSSD-10's capabilities.⁴⁷⁷ On the 22d, the DSC sent CSSD-10 boxes of new cargo straps and banding material. After six months in the desert, the cargo straps that came with the trailers were worn-out, causing as much as 50 percent of a load to bounce off the backs of trucks and trailers traversing rough desert roads. Just prior to the assault, General Krulak sent CSSD-10 PLRS, GPS, and night vision goggles.^{478*}

Early on the 19th, Lieutenant Colonel Kelly sent his security force and engineers one kilometer from the border to OP-4, near the site of Task Force Shepherd's victory over the Iraqis in late January. Using 13 bulldozers, the engineers dug in positions and were joined over the next four days by the remainder of the CSSD and CSSD-13.⁴⁷⁹ CSSD-13 set up next to CSSD-10's ammunition dump, where Captain Kava laid out, dug in, and bermed CSSD-13's dumps and camps. Two companies from Task Force Grizzly screened OP-4 and Task Force Shepherd bolstered the defenses by collocating its logistics train and eight LAV-25s with CSSD-10.⁴⁸⁰ The CSSD's security platoon, under Captain Dennis

*In addition to providing the DSGs' equipment, the DSC's supply detachment exchanged 439 items of working equipment for broken items with the owning units. (DSC ComdC 16Feb-12Mar91, Sec 2)

Muller, prepared to repulse any raid by Iraqi special operations forces and everyone was wary of the Iraqi artillery threat, which was demonstrated by a barrage fired at a Marine reconnaissance team, just 1,000 meters from the CSSD.

The 23d was a busy day for CSSD-10 as capabilities were fine-tuned and supplies were picked up, pushed, and pulled. The CSSD-10 truck detachment completed delivery of 1,700 rounds of artillery ammunition to the 11th Marines, then loaded 12,000 more rounds to move with the regiment into Kuwait.⁴⁸¹ Throughout the day, the 8th Motor Transport Battalion supplied water, fuel, MREs, and ammunition to OP-4, while Kelly sent convoys to Khanjar to pull fuel and water, and to Kibrit for water. By the end of the day, CSSD-10 had 97,692 meals, 62,000 gallons of fuel, 24,800 gallons of water, and one-day's worth of ammunition on hand. CSSD-10's ammunition technicians organized munitions into task force packages for easy distribution to the mobiles and the military police completed final preparations at the enemy prisoner of war transfer point. Although not a combat service support function, CSSD-10 prepared a hasty wash-down site to decontaminate any units attacked by chemical weapons at the first obstacle belt.⁴⁸² Major Lucenta distributed to the convoy commanders five night vision goggles, three Position Locating and Reporting Systems (PLRS), and one Global Positioning System (GPS), forwarded by General Krulak. One collecting and clearing company opened another operating room and the second company boxed its equipment in preparation for its move through the breaches in the minefields on the following day.⁴⁸³ At 2200, the medical mobile of HMMWV ambulances and busses departed OP-4 with Colonel Powell in the lead.⁴⁸⁴

On the 23d, as well, CSSD-13 laid out helicopter deliverable resupply

A 1st FSSG briefing slide shows the disposition of Marine forces in February 1991.

Photo courtesy of LtGen James A. Brabham, Jr.



packages and scheduled helicopters. CSSD-13's operations officer, Captain Brown, built 4,000-pound packages that could be lifted by a Boeing CH-46 Sea Knight helicopter. To use the massive lift capability of the Sikorski CH-53E Sea Stallion helicopter, Brown planned to sling more than one package under the giant chopper. Captain Ritchie, the CSSD commander, ordered that a block of MOPP equipment be ready to fly to any unit attacked by chemical weapons.⁴⁸⁵ Brown scheduled one resupply per day for each of the task forces, knowing that the foot-mobile units would take what they needed and leave what they could not carry. First Lieutenant Darryl L. Smith, the CSSD landing zone support officer, organized the landing zones by laying out resupply packages and netting loads just prior to a mission.⁴⁸⁶

Two days before, MCSSD-17 had followed Task Force Ripper to its attack positions 15 kilometers southwest of the Kuwaiti border. Captain Winter, the mobile commander, still short of trucks and uncertain about the ammunition requirements for the task force, used the last few days to obtain more equipment and to try to improve his security. He informally tried and failed to obtain TOW missile vehicles and he formally requested and received approval for, but never obtained, four amphibious assault vehicles from the Prepositioned War Reserve. Winter wanted to use the amphibious assault vehicles as replacement items and to haul the infantry from Company C, 1st Battalion, 25th Marines, which he had agreed to transport. Instead, the CSSD commander used his trucks to transport the infantry whose presence enhanced security, but reduced his ability to haul supplies. Benefitting from the DSC's pre-G-day equipment reinforcements, MCSSD-17 received one of the 5,000-gallon refuellers, which increased its fuel-hauling capacity to 23,500 gallons and a couple of LVSs which offset the loss of trucks that Winter gave the task force to carry line-charges for the breaching operation. In addition, MCSSD-17 received a crane which helped ease the loss of two, broken down, of its three RT 4000 forklifts.⁴⁸⁷

On the 23d, while Task Force Ripper moved to the berm, MCSSD-17 picked up supplies at OP-4 and then delivered fuel, water, and ammunition to the task force battalion logistics trains. With the exception of the 3d Tank Battalion, Colonel Fulford, the task force commander, consolidated all the battalion logistics trains into a single task force convoy for movement through the obstacle belts. MCSSD-17 delivered 6,000 gallons of water, 4,500 gallons of fuel, and one-day's worth of ammunition to the 1st Battalion, 7th Marines, and similar amounts to Ripper's other battalions.⁴⁸⁸ The task force carried two days of supply in most commodities, four days of MREs, a basic allowance, and a day's allowance of ammunition. Late in the evening, Captain Winter sent trucks to OP-4 to pick up the additional amounts of ammunition that Ripper wanted and that I MEF had earlier disapproved. The delayed loading of the ammunition diverted MCSSD-17's focus on supporting ground operations the following day.⁴⁸⁹

The last day before the ground war started early for MCSSD-11. After adjusting loads and dealing with some maintenance problems, First Lieutenant Juan C. Osorno's Bravo Train departed for CSSD-10 at 0400 to pick up ammunition for delivery to Task Force Papa Bear. Later in the morning, the Bravo Train

transferred 280,000 rounds of small arms ammunition, 30 TOWs, 25 Dragons, 45 AT-4s, and 40 LAAWs to the task force, whose battalion logistic trains remained with their units. At 0800, the Alpha Train, commanded by First Lieutenant Delaney C. Williams, drove to CSSD-10 to pick up fuel, water, and MREs, then distributed the supplies to the task force. After completing the resupply missions, both trains returned to CSSD-10 to load a day's worth of supplies to carry into Kuwait. While MCSSD-11's convoys picked up supplies, Captain Burke, the mobile commander, and his key personnel went to meetings and discussed Papa Bear's final combat plan, ammunition resupply, prisoner of war handling, and casualty evacuation procedures. Late in the evening, Colonel Powell, leading the medical mobile and a communication retransmission team, joined MCSSD-11 which was ready to move into Kuwait. At midnight, Burke dispatched a section of trucks from the Alpha Train to CSSD-10 to pick-up Papa Bear's additional block of ammunition.⁴⁹⁰

Combat Service Support Detachment 91

I MEF's move to the west took away CSSD-91's advantage of being centrally located to both divisions. Despite the extension of the distance required to transport prisoners from the battle zone, CSSD-91 remained at Kibrit, continued to prepare for war, and received unexpected help from the U.S. Army. Because of Saudi desires to handle Iraqi prisoners, the U.S. Army found itself with a spare military police battalion from the Puerto Rican National Guard. ArCent sent the 350 soldiers of the 34th Military Police Battalion (-) to CSSD-91, where Lieutenant Colonel Sparrow assigned them to guard Iraqis.⁴⁹¹ In addition, the Army drivers responsible for bussing prisoners to Army compounds, lived at CSSD-91. By the start of the ground war, the size of CSSD-91 reached 850 officers and enlisted men, of whom two thirds were soldiers. Also during the month, English-speaking Kuwaitis joined the CSSD which increased the number of translators to 25. Sparrow was glad to have the extra help, but took measures to ensure that vengeful Kuwaitis would not harm captured Iraqis. As the ground war drew nearer, small numbers of surrendering and captured Iraqis were smoothly processed through the camp and transported south. GSG-2 at Mishab sent the CSSD fuel and water and the 1st FSSG pushed forward rice, beans, and blankets to prepare for the huge influx of expected prisoners. Right before the start of the ground war, the 1st FSSG assigned CSSD-91 the additional mission of transporting captured Iraqis from the division holding areas in Kuwait to Kibrit. This new responsibility sent Lieutenant Colonel Sparrow unsuccessfully scrambling for trucks and drivers at the last minute.⁴⁹²

MWSG-37 and the Seabees Final Preparations

During the last week before the ground war, the 3d NCR completed projects, unit relocations, and developed plans to move into Kuwait behind the ground forces. When the DSC engineers moved to the berm, NMCB-24 picked up

the responsibility for maintaining the Al Khanjar Highway which connected CSSA-2 with the Saudi berm. After G-day, Captain Johnson planned to move his forward headquarters into Kuwait and collocate with the MEF headquarters at Al Jaber Air Base. NMCBs -5 and -24 would advance with him to Al Jaber, build the MEF headquarters and a Seabee Camp, repair runways and restore services at Al Jaber, Kuwait International Airport, and As Salem Air Base, which was located west of I MEF's zone of action. NMCB-5 would work from Al Jaber and NMCB-24 would use Kuwait International airport as a base.⁴⁹³

The week prior to G-day, MWSG-37 completed its preparations to support the ground war. MWSS-374 modified the aviation ammunition supply point and refuelling capabilities at Jubayl Naval Air Facility which allowed 3d MAW's F/A-18 jets to rearm and refuel 170 kilometers closer to Kuwait than Shaikh Isa. On the 20th, Colonel Coop sent MWSS-271 and -273 additional equipment, stripped from the southern MWSSs, and on the 23d, established two FARPs on the border to support helicopter operations. CSSD-10 assisted MWSS-271's 28-Marine mobile FARP become operational next to CSSD-13.^{494*} After the capture of MEF Objectives A and C, Colonel Coop planned to establish a FARP at Al Jaber Air Base to refuel both helicopter aircraft groups and to send MWSS-374 to Kuwait International Airport.⁴⁹⁵

Conclusion

*Above all else, the division must not unnecessarily lose momentum due to logistics. All of our actions must be driven by this requirement.—
Col Alexander W. Powell*

By day's end on 23d February, the DSC had pushed its assets as far forward as possible to support the coming assault. Trucks from the 8th Motor Transport Battalion and DSG-1 and -2 were forward with the artillery regiments and all MCSSDs were staged with their regiments and task forces, ready to roll into Kuwait. Elements of DSC's engineer battalions were on the point of the attack with the division engineers, prepared to breach the Iraqi defenses while the bulk of both engineer support battalions were ready to move into the breach. MWSG-37 pushed FARPs forward to refuel 3d MAW's helicopters and the Seabees were staged to repair Kuwait's airfields. At midnight on the 23d, I MEF was logistically ready to throw Iraq out of Kuwait.

*According to Col Kelly, the FARP arrived unexpectedly and "needed everything." CSSD-10 brought them under its wing and provided them MREs and dug them in. (Kelly comments)

The Ground War: 24-28 February 1991

G-Day: 24 February 1991

I MEF began the assault at 0400, aimed directly at its ultimate objective, al-Mutl'a Pass (aka Al Jahra) and the roads leading from Kuwait City, 35 to 50 miles to the northeast. I MEF faced the strongest concentration of enemy defenses in theater.⁴⁹⁶

In the early hours of 24 February, I MEF's assault forces crept towards the border under the cover of darkness and crossed into Kuwait to breach the double lines of Iraqi obstacles. In the 1st Marine Division's zone of action, combat engineer teams, including Company A, 7th Engineer Support Battalion, from the DSC, cleared the path for Task Forces Ripper and Papa Bear, who were to launch the main attack, while Task Forces Taro and Grizzly protected the division flanks. MCSSDs -11 and -17 followed closely behind the two mechanized task forces, while the 11th Marines, with its fleet of DSC and CSSD-10 ammunition

DSC positions at the beginning of G-Day: 24 February 1991

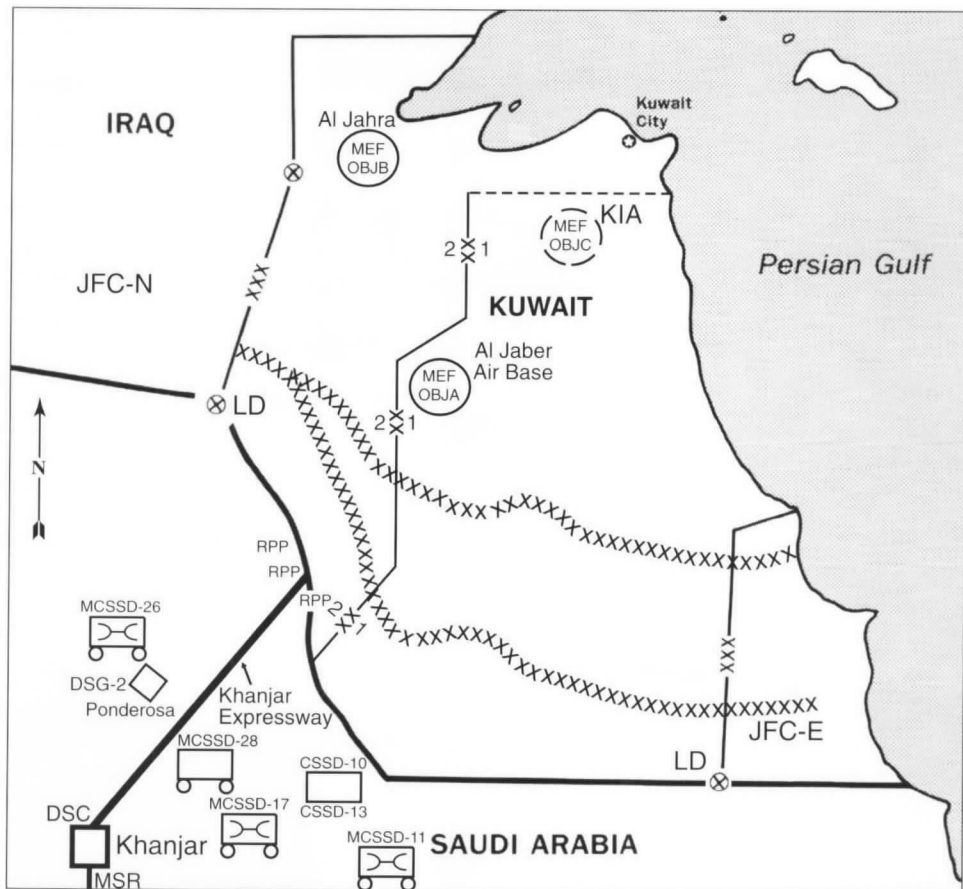

trucks, fired artillery missions and moved forward into Kuwait. To the west, in the 2d Marine Division zone of action, Task Force Breach A, which included Company B, 8th Engineer Support Battalion, from the DSC, advanced in front of the 6th Marines and MCSSD-26, while the 10th Marines fired artillery and drove forward with its fleet of ammunition trucks provided by the DSC and DSG-2. The ground war had begun and the DSC's forces were far forward and intermingled with the assault elements.

The 2d Marine Division Zone of Action

Throughout the night, the 6th Marines topped off with water and fuel at DSG-2's RRP's, and moved to penetrate the Iraqi obstacle belts in Kuwait.* At midnight, both serials from MCSSD-26 drove 15 kilometers east from RRP Stewart to tactical assembly areas seven kilometers from the Kuwaiti border. At 0420, Lieutenant Colonel Wittle, the MCSSD commander, leading Serial 1, linked up with Battery D, 2d Battalion, 10th Marines, in front of the breach lane marked Blue 3. About the same time, Major Charles J. Clarke, the MCSSD executive officer, leading Serial 2, had joined Headquarters Battery, 2d Battalion, 10th Marines, across from Blue 4. A little more than an hour later, engineer teams attached to each of the three assault battalions began cutting through the first obstacle belt. Captain Hearnberger's Company B, 8th Engineer Support Battalion, drove its armored Ninja Bulldozers 16 kilometers from Saudi Arabia straight into the first minefield and, at 0600, began proofing, clearing, widening, and marking the breach lanes.^{497**} In order to keep the 6th Marines moving, Staff Sergeant Daniel A. Kur, a breach team leader in Company B's first platoon, picked up mines with his bare hands and removed them from the lane.^{498***}

At 0500, both serials from MCSSD-26 started towards Kuwait, crossed the border at 0630, and entered the breach at 0715. Serial 1 shifted to Red 2, because Blue 3 was closed, while Serial 2 proceeded as planned through Blue 4. At 0905, both serials came under artillery fire which lasted until 0945. While passing over one of the high-pressure gas lines that zigzagged through the area, a CUCV pickup truck belonging to Serial 1 hung up on the pipeline. The LVS in front of the vehicle immediately tried to pull the CUCV across, but snapped its tow line in the effort. Then, a second LVS pushed the stranded vehicle forward,

*DSG-2's RRP's were augmented by 5,000-gallon refuelers from the 8th Motor Transport Battalion. (Woodson intvw, 19Mar96)

**The Company B bulldozers moved "in-stride" directly into the paths blown by the 2d Marine Division's line charges and plows and proofed, smoothed, and widened to 15 feet the 100-meter-long lane through the breach in two minutes. Company B used two armored Ninja Bulldozers with the wedge shaped blades fabricated by the Zahaid Caterpillar distributor of Jubayl and two straight-blade models to accomplish its mission. (Skipper comments)

***Usually, the bulldozer blades pushed the mines harmlessly to the side of the lanes where engineers destroyed them with TNT charges, after traffic cleared the lane. (Skipper comments)



Photo courtesy of LtGen James A. Brabham, Jr.

A line of Iraqi mines in Kuwait greeted I MEF's attacking elements. The Iraqis laid two series of minefields which elements of the 7th and 8th Engineer Battalions helped to breach.

but bent the hydrogen-sulfide pipeline without freeing the CUCV. Not wanting to rupture the pipeline and cause an explosion, Lieutenant Colonel Wittle halted the operation and ordered an M936 wrecker to lift the CUCV off the obstruction. After freeing the pickup truck, the mobile's M88A1 tank retriever used its bulldozer blade to push sand over the pipe, which allowed the serial and subsequent traffic to pass. The entire vehicle recovery and route repair operation took 12 minutes.⁴⁹⁹

After emerging from the minefield at 1140, Serial 1 headed for a pre-planned position, but stopped after one kilometer because of a tank battle to its front and right flank.* While halted, Serial 1's Marines exchanged fire with the enemy and captured 27 prisoners to include the commanding general of the *14th Infantry Division (Commando)*. MCSSD-26 seized three dozen weapons, a cache of ammunition, maps, overlays, and the division's communications center including the enemy's call signs and frequencies.** After Serial 2 arrived, Lieutenant Colonel Wittle established RRP Fournier, named after Captain David E. Fournier, MCSSD's tactical coordination officer. Wittle ordered his troops to dig in using the Iraqi trenches they had just cleared and begin resupplying individual vehicles and units passing through the area. MCSSD-26 stayed at RPP Fournier until the next morning, ducking incoming Iraqi artillery fire, dispensing water, fuel, and MREs, and treating the injuries of six Marines and four Iraqi wounded.⁵⁰⁰

After the 6th Marines moved into Kuwait, the 2d Tank Battalion, the

*LtCol Wittle monitored the regimental radio nets and was fully aware of the tactical situation facing the 6th Marines.

**MCSSD-26 captured a ZPU-1 antiaircraft gun which was returned to the United States and is displayed outside of the office of the Commandant of the Marine Corps at the Pentagon. (Warker comments)



Photo courtesy of Maj Peter M. Warker

A TOW-mounting HMMWV leads MCSSD-26 through an Iraqi minefield. The low thin cloud that parallels the horizon is the smoke from an exploding line charge used to clear a path through the mines.

division's reserve, topped off at DSG-2's RPPs and moved into the first minefield. Following closely behind the tanks, Lieutenant Colmenares, commander of DSG-2's collecting and clearing station, and his security officer led 15 military policemen and some communicators to a point in front of the entrance to Red 1.⁵⁰¹ At this location, Iraqi soldiers opened fire on the group which returned suppressing fires, captured 45 Iraqis, and then established radio contact with the Ponderosa and a medical treatment area.⁵⁰² Meanwhile, the command elements of the 2d Marine Division and the 10th Marines, refreshed at DSG-2's RPPs, advanced into the breach, and were followed into Kuwait by the Tiger Brigade. While the scheduled waves of the division advanced through the obstacle belts, Lieutenant Colonel Hering, commanding officer of DSG-2's northern transfer point, waited all day and night with his convoy, seven kilometers west of the Kuwait border.⁵⁰³ Back at the Ponderosa, Major Sass, DSG-2's operations officer, obtained two 5-ton trucks from the DSC which evacuated the prisoners captured by Colmenares.⁵⁰⁴

At 0900, Lieutenant Colonel Head relocated his MCSSD-28 eight kilometers northeast of his assembly area, joined the 8th Marines combat train, and waited to move to the breach assembly area.⁵⁰⁵ While at the new location, the mobile loaded 100 Marines belonging to the 2d Battalion, 4th Marines, and the 3d Battalion, 23d Marines. In addition to using MCSSD-28, Colonel Schmidt, the 8th Marines commander, hauled infantry on the trucks of the regimental logistics train, but still had to leave 50 Marines in the assembly area when the lead battalions advanced at 1530. Two hours later, MCSSD-28 departed with the regimental logistics train for a 17-kilometer road march to Assembly Area Blue B.⁵⁰⁶ After arriving at 2200, MCSSD-28 tried to repair a CUCV pickup truck for the 1st Battalion, 8th Marines; ordered AAV parts from DSG-2 for the 2d Battalion, 4th Marines; and waited until morning to move into Kuwait.⁵⁰⁷

On the 24th, Lieutenant Colonel Skipper moved his jump command post and Companies A and C, 8th Engineer Support Battalion to the Saudi Berm between Blue Lanes 3 and 4. Skipper ordered Company C to punch a 50-meter



Photo courtesy of Maj Peter M. Warker

An M1A1 Abrams tank of the 2d Tank Battalion races past MCSSD-26 in Kuwait.

hole in the berm and Company A to extend the Khanjar Expressway through the new opening into Kuwait. While the two letter companies completed their tasks, the engineer battalion commander listened to the intelligence and operation nets, used his map and PLRS, pieced together an accurate picture of the tactical situation in Kuwait, and waited impatiently to move to Al Jaber Air Base and establish the DSC's transfer point.⁵⁰⁸

Table: DSC commands and commanders

DSG-1		DSG-2	
Command/Unit	Commander/OICS	Command/Unit	Commander/OICS
DSG-1	Col Alexander W. Powell	DSG-2	Col Thomas P. Donnelly, Jr.
Command Element	LtCol Leon S. Luszczynski	MCSSD-26	LtCol David L. Wittle
CSSD-10	LtCol Richard L. Kelly	MCSSD-28	LtCol James W. Head
CSSD-11	Capt Adrian W. Burke	Northern Transfer Point	LtCol John C. Hering
CSSD-13	Capt William H. Ritchie, III	RPPs	Capt Carl D. Matter
CSSD-17	Capt Edward J. Winter	Medical Mobile Retrans Team	1stLt Antonio Colmenares
Medical Mobile	Ensign William C. Hancock		
Retrans Team	Capt Jeffery J. Morsch		

The 1st Marine Division Zone of Action

At midnight, Task Force Ripper pushed in a wedge formation into Kuwait, overcame light resistance, and easily breached the first obstacle belt by mid-morning.⁵⁰⁹ Delayed by the requirement to pull Ripper's additional ammunition from OP-4, MCSSD-17 departed Saudi Arabia behind schedule at 0615, but rapidly passed through the first obstacle belt abreast of the artillery and ahead of Ripper's logistics trains. While in the breach, the mobile ducked sporadic Iraqi artillery fire directed at Task Force Papa Bear which could be seen conducting breach operations to the east of Ripper.⁵¹⁰ At 1000, MCSSD-17 caught up with Ripper's command element and dropped off the Reserve infantrymen who established a prisoner of war camp between the obstacle belts. At 1125, Task Force Ripper penetrated the second minefield against light resistance and was greeted on the far side by a deluge of surrendering Iraqis. After passing through the second defense line at 1400, MCSSD-17 advanced to a position seven kilometers west of the breach and set up to support the attack on the Al Jaber Air Base. Captain Winter, the mobile commander, chose this position on the western edge of Ripper's zone of action to avoid the danger of ambush from the burning Burqan oil fields to the east. On arrival, Winter's first sergeant led a team that cleared nearby Iraqi positions and captured 35 prisoners of war, a large cache of weapons, and an Iraqi communications plan, which the Marines forwarded to CSSD-10.⁵¹¹

Less than three hours after Task Force Ripper departed for the first obstacle belt, Captain Burke ordered his MCSSD-11 to "move out" in two columns "echeloned right," "guns right," and "scouts right." In trace of MCSSD-11, Colonel Powell led CSSD-10's medical mobile and a communications retrans-

MCSSD-11 traverses the breach. The smoke in the distance is from the burning oil wells that barely can be seen as small points of light on the horizon.

Photo courtesy of Maj Adrian W. Burke



mission team. Almost immediately after starting, darkness forced the mobile commander to reform MCSSD-11 into a single and more controllable formation. After moving nine kilometers, the column stopped at 0520 to await its turn to move through the Saudi Berm. At 0800, MCSSD-11 fell in behind the 1st Tank Battalion's logistics train, crossed the berm, and reached Kuwait at 0936. At the border, Captain Burke left the convoy with two trucks carrying 800 rounds of 81mm mortar ammunition for the 3d Battalion, 9th Marines and looked for Task Force Papa Bear's logistics operations center. Before departing, he directed MCSSD-11 to move to a location 10 kilometers northeast of the border and wait for his orders. After driving 10 kilometers, Burke found the 3d Battalion, 9th Marines' field trains and transferred the mortar ammunition. He then drove northeast another five kilometers where he found Major Gary M. Reinhold, Papa Bear's logistics officer, controlling movement through the first obstacle belt. Told to move through the breach, Burke called forward the mobile, which had been rejoined by the Alpha Train's ammunition trucks with Papa Bear's additional ammunition.

Just forward of MCSSD-11's position, Captain Philip L. Salinas, commanding officer of Company A, 7th Engineer Support Battalion, directed the breaching, proofing, and marking of lanes in the first obstacle belt. Salinas and his engineer company were part of the Engineer Detachment, 1st Combat Engineer Battalion, assigned to Task Force Papa Bear. Major Joseph I. Musca commanded the detachment and placed Salinas in command of the Support Breach Team (SBT), which consisted of his company, and elements from the 1st Combat Engineer Battalion and the 3d Amphibious Assault Battalion. Half of the SBT rode in amphibious assault vehicles while the other half travelled in trucks. After the 3d Battalion, 9th Marines, and Company A, 1st Combat Engineer Battalion, penetrated the first obstacle belt in two places, the SBT breached and proofed two additional lanes and marked all thoroughfares with colored tape and chemical lights. At 1330, Salinas led the SBT to Papa Bear's field trains south of the second obstacle belt where it constructed a berm around the regimental aid station, and remained there until the next day.⁵¹² Behind the SBT, the 7th Engineer Support Battalion moved into the first obstacle belt and improved and widened breach lanes throughout the 1st Marine Division's zone of action.⁵¹³

While Captain Salinas' engineers marked the lanes, Captain Burke's MCSSD-11 crossed the first obstacle belt on lane 1, ahead of the 1st Battalion, 11th Marines. Stopping on the north side of the Iraqi minefield to wait for Papa Bears' logistics' operations center, MCSSD-11 set up a hasty defense and internally redistributed the ammunition brought forward by the Alpha Train for delivery to the Task Force. After waiting three hours and twice going to MOPP-4 due to erroneous reports of chemical attacks, the mobile fell in behind Ripper's logistics operation center and moved within 6,500 meters of the second obstacle belt. Still behind MCSSD-11, Colonel Powell ordered Captain Jeffrey J. Morsch, DSG-1's operations officer, to set up the retransmission site and establish communications between the northern and southern CSSDs. Powell, having one of the few Position Locating and Reporting System (PLRS) sets in the DSG, left Morsch

in charge and led an ambulance to MCSSD-17's location to medevac two wounded Marines from Task Force Grizzly.^{514*}

Fifteen kilometers northwest of MCSSD-11, Captain Winter deployed MCSSD-17 in the inverted triangle formation with his two mini-mobiles oriented north towards the enemy and the command element located to the south. Winter quickly ordered the D-7 bulldozer to scoop out a prisoner-of-war compound in the middle of the position and manned it with the only three Marines he had available. Iraqi soldiers drifting into the area throughout the remainder of the day and night were met by the Marines, disarmed, and guided to the prisoner of war compound.** While MCSSD-17 wrestled with the Iraqi prisoners, Task Force Ripper isolated Al Jaber Air Base and waited for Task Force Grizzly to attack the objective. During the remainder of the day, MCSSD-17 pushed 10,000 gallons of water and 10,300 gallons of fuel to Task Force Ripper; the 3d Battalion, 11th Marines; and the 3d Battalion, 12th Marines, which supported Task Force Grizzly.^{515***} In the late afternoon, Lieutenant Colonel Kelly, CSSD-10's commanding officer, arrived at MCSSD-17 and decided to establish a combat service support area at the same location. Kelly contacted Major Howard E. Rice, Jr., CSSD-10's executive officer, and told him to prepare elements of the CSSD to move into Kuwait on the 25th.⁵¹⁶ Following Kelly's visit, Colonel Powell arrived at MCSSD-17 with DSG-1's ambulances and dispatched two wounded Marines and four injured Iraqis to OP-4. Powell then remained overnight with the mobile.⁵¹⁷

After setting up in the triangle defensive formation south of the second obstacle belt, Captain Burke's MCSSD-11 dispensed combat service support over the entire breadth of the division's zone of operation. Responding to a request from DSG-1 to supply Task Force Grizzly, which was on the other side of the division's area of operations, Burke ordered 1st Lieutenant Delaney C. Williams, commander of the Alpha Train, to supply first Papa Bear's logistics operations center and then resupply Grizzly. Missing the operations center in the fog, the Alpha Train continued west, crossed two regimental boundaries, and was sporadically and ineffectively shot at by the Iraqis. Williams supplied Grizzly with 3,200 gallons of fuel and 2 pallets of MREs. While the Alpha Train traversed the division's zone, Burke sent the Bravo Train, led by First Lieutenant Juan C. Osorno, to distribute 2,700 gallons of fuel and 1,600 gallons of water to the combat engineers and the 3d Battalion, 9th Marines.⁵¹⁸

*PLRS was an automated navigation aid which operated with Marine Corps radios. A master station using the UHF frequency band, coordinated all signals in a particular area. Besides giving positioning information, PLRS was used as an alternate means of communications.

**According to Capt Winter, "Iraqis drifted out of the fog into MCSSD-17's position throughout the night. Fire discipline was a concern for the Marines on the perimeter who wanted to protect the mobile from the hostiles without shooting the friendlies." (Winter comments)

***MCSSD-17's aggressive support to Task Force Ripper was not always appreciated. 1stLt Edwin E. Middlebrook moved a refueler into one of the jump-off positions for the attack on Al Jaber Air Base, where he was told to leave because of the explosiveness of the fuel. (Winter comments)

Back in Saudi Arabia at OP-4, the 24th was a day of anticipation, preparation, and processing of prisoners of war. Waiting for its trucks to return from the 11th Marines, CSSD-10 loaded its few available vehicles to resupply MCSSDs -11 and -17 the following day. Each resupply convoy would carry 20,000 gallons of fuel, 5,400 gallons of water, ammunition, and one-day's supply of MREs. After receiving Lieutenant Colonel Kelly's order to move forward, Major Rice began organizing a detachment to send to MCSSD-17's location. During the day, Company B, 1st Battalion, 25th Marines dropped off 111 enemy prisoners of war taken during Task Force Grizzly's infiltration of the first obstacle belt.⁵¹⁹ CSSD-10's military police detachment processed and transferred these prisoners and 12 others to the DSC holding pen at Khanjar.⁵²⁰

During the morning, Captain Ritchie's CSSD-13 successfully helilifted resupply packages to Task Forces Taro, Grizzly, and Shepherd and enjoyed some good fortune. At OP-4, MWSS-271's mobile FARP, which set up next to CSSD-13 to support MAG-16, gave Ritchie close access to helicopter operations.⁵²¹ Another piece of luck was that CSSD-13 had good communications with the division and could both monitor the tactical situation and talk to the supported units. The CSSD commander attributed this success to the leadership and technical ability of Corporal Andrew S. Jericho, a wireman who tapped into the division's radio nets.* At noon, Task Force Taro requested an emergency resupply of water. By 1500, CSSD-13 successfully helilifted two pallets of bottled water to Taro on the division's eastern flank.⁵²² At the end of the day, Ritchie reviewed the day's resupply operations and tactical situation, while his operations officer, Captain Brown, scheduled the next day's resupply missions with the 3d MAW.

G+1: 25 February 1991

On G+1, I MEF advanced against the fiercest resistance it encountered during the ground offensive.⁵²³

On 25 February, the 1st Marine Division prepared to seize Al Jaber Air Base and then deploy north towards Kuwait International Airport. To support the division's extended operations, CSSD-10 planned to move to MCSSD-17's position near Al Jaber. To the northwest, the 2d Marine Division aimed at bringing the 8th Marines through the obstacle belts and then attacking north towards Al Jahra with all three maneuver units. In support, DSG-2 intended to establish a transfer point to distribute supplies to both mobiles and to provide a maintenance capability near MCSSD-26's position. On the front lines in Kuwait, the mobile CSSDs prepared for the second day of combat.

The 2d Marine Division Zone of Action

During the morning, MCSSD-26 resupplied the 6th Marines and replen-

*In addition to supporting CSSD-13, Cpl Jericho and his 11 communicators relayed messages for both divisions and the DSGs. (Ritchie comments)



Photo courtesy of LtCol William H. Ritchie, III

At the far left of this picture is Cpl Andrew S. Jericho of the CSSD-13 Communication Section, who used creativity and persistence to maintain communications during the advance. Capt William Ritchie III, the commander of CSSD-13, is at the far right.

ished its own stock of supplies. The mobile delivered 11,000 gallons of water, 4 pallets of MREs, TOW missiles, 40mm grenades, .50-caliber ammunition, and its remaining 16,500 gallons of fuel. Every unit received fuel, but not as much as it wanted.⁵²⁴ Accordingly, Lieutenant Colonel Wittle requested resupply of water, fuel, and ammunition from DSG-2. At 0900, CH-53 Sea Stallion helicopters, which mistook MCSSD-26 for the Tiger Brigade, dropped water, fuel, and MREs.⁵²⁵ Two hours later, Lieutenant Colonel Hering, DSG-2's executive officer, arrived with his convoy at RRP Fournier, established the northern transfer point, and gave all his water and fuel to MCSSD-26. Later, helicopters carrying 60 TOW missiles, 3,000 rounds of .50-caliber machine gun ammunition, and about 1,000 rounds of 40mm ammunition arrived from Khanjar. Wittle rapidly distributed the munitions to the 6th Marines.⁵²⁶

After the morning's resupply operations, Lieutenant Colonel Wittle moved MCSSD-26 north to Phase Line Red in preparation for the 6th Marines' assault to Phase Line Horse.* Wittle planned to move Serial 1 north of the

*Phase lines are used to control the movement of units on a battlefield. The 2d Marine Division designated numerous phase lines, including Phase Lines Red and Horse, for common reference.

Abdullea Road and then bring forward the second serial. Wittle left First Lieutenant Walter T. Anderson and his landing support detachment with Serial 2 to receive supplies by helicopter.* At 1430, with the enemy still in the area, Serial 1 slowly moved north, hampered by poor visibility from the overcast sky and the burning oil fires. Because of the loss of PLRS and GPS navigational data in the division's zone of action, Wittle reverted to map and compass, skills learned years before at The Basic School, to guide his convoy to a position 500 meters north of the East-West Abdullea road where they stopped for the night.** The visibility was so bad that the Marines walking in front of the convoy periodically stopped and scraped a swath of sand away from the ground until they found the asphalt of the road. Concerned that Serial 2 might get lost in the dark, Wittle ordered Major Clarke to remain at Phase Line Red until the next morning.⁵²⁷

Back in Saudi Arabia, MCSSD-28 started the morning by sending a request to DSG-2 for two AAVs from the prepositioned war reserve and then advanced with the 8th Marines logistics train northeast into Kuwait. The mobile and the logistics train moved together in a giant convoy behind the 2d Battalion, 4th Marines. When the line of trucks approached the entrance to Blue 4 at 0730, it was stopped by the military police who considered turning the convoy around in favor of approaching combat units, but then allowed the convoy to proceed after gaining an appreciation for its huge size and importance. After exiting the first belt of mines at 0900, Lieutenant Colonel Head, the mobile commander, established a refuelling site for Company C, 4th Tank Battalion, which was rushing forward to join 8th Marines as the regimental reserve. Ordered to relocate without refuelling the tanks, MCSSD-28 packed its equipment and drove 28 kilometers to establish a hasty combat service support area on the far side of the second minefield.

After crossing both obstacle belts and reaching Phase Line Red, the 8th Marines attacked north on the right flank of the 6th Marines to Phase Line Horse.⁵²⁸ MCSSD-28 remained in position north of the second belt of mines, resupplied the 8th Marines, and awaited replenishment from DSG-2. The first customer served by MCSSD-28 was Company C, 4th Tank Battalion, whose tanks finally emerged from Blue 4 enroute to the line of departure. At 1100, MCSSD-28 sent 15 TOW missiles to the 1st Battalion, 8th Marines, which had returned to the 8th Marines operational control after breaching the minefields with the 6th Marines. Two hours later, MCSSD-28 called DSG-2 for an emergency resupply of TOW missiles and tank rounds and prepared a landing zone to receive the munitions. After waiting two hours while Iraqi artillery exploded within 200 meters of the mobile's command post, resupply helicopters arrived, unloaded unrequested water and unneeded line charges, but no ammunition. At 1600, MCSSD-28 sent refuelers to the logistics trains of the 1st Battalion, 8th Marines,

*On the 25th, MCSSD-26's Red Patch Marines recovered supplies from 13 helicopter support missions.(MCSSD-26 Sitrep 24Feb-1Mar91)

**The Basic School at Quantico, Virginia, provides newly commissioned Marine second lieutenants their first schooling as officers in the fundamental tactical skills of their profession.

and the 2d Battalion, 4th Marines, while the regimental logistics train transferred wounded Iraqis to the mobile in preparation for the attack.* Lieutenant Colonel Head sent trucks carrying most of his remaining supplies of fuel, water, and ammunition with the logistics train and remained behind to retrieve refuelers, await resupply from DSG-2, and to medevac the wounded Iraqis.

Earlier that morning, Lieutenant Colonel Hering had established DSG-2's northern transfer point at RRP Fournier and was surprised by MCSSD-26's need of supplies so soon. After resupplying the mobile, the northern transfer point needed to replenish its stocks of water and fuel, but did not have communication with DSG-2 at the Ponderosa, which was 45 kilometers away and out of range of the VHF radios. Earlier in the day, Colonel Donnelly had ordered Lieutenant Colmenares to move the collecting and clearing and radio relay stations to the northern transfer point which broke the communications link with the rear. After Colmenares moved, Hering was unable to call for replenishment, pass emergency requests for ammunition received from both mobiles, and forward a request from MCSSD-28 to medevac Iraqi wounded. At Khanjar, the DSC heard the requests from the mobiles for resupply. Making separate trips to the Ponderosa, Colonel Woodhead, the DSC's chief of staff, and Lieutenant Colonel O'Donovan, the DSC's assistant operations officer, carried the mobiles requests to DSG-2, ordered that bulk fuel and water trucks be reconfigured, and sent into Kuwait.** Receiving no resupply on the 25th, Hering spent the afternoon watching helicopters deliver ammunition from the DSC and medevacing wounded while regretting that he had brought forward such a large maintenance detachment and had not used the trucks to carry water, fuel, and tank-killing ammunition.⁵²⁹

At 1900, Lieutenant Colonel Head began to prepare MCSSD-28 to follow the 8th Marines and again requested replenishment from DSG-2. The Iraqis underscored the need to move by shooting artillery into the area and damaging one of the mobile's LVSSs. The bad visibility from the oil fires and weather, the coming of night, the loss of GPS and PLRS navigation data, and the need to reload ammunition staged on the ground, nevertheless, delayed the displacement. Head maintained communications with the regimental logistics train and the northern transfer point, but not with the Ponderosa. At 2000, MCSSD-28 again requested replenishment from the transfer point which was located five kilometers northwest of MCSSD-28. Hering informed Head that he could neither push supplies to the mobile nor pass his request to DSG-2 since he did not have communications with the rear. At 2200, Lieutenant Colonel Head lined up his nearly empty mobile and waited all night for the 8th Marines to order him forward.⁵³⁰

Lieutenant Colonel Skipper, the commanding officer of the 8th Engineer

*On the 25th, the Marines from the 2d Battalion, 4th Marines, were replaced with Marines from the 3d Battalion, 23d Marines, keeping the number of infantry Marines carried by MCSSD-28 during the ground war at 100.

**There is no record of these trucks reaching either the mobiles or the transfer point on the 25th. Six years after the fact, LtCol Matter, DSG-2's motor transport officer, remembered the "hot tasker" from Col Woodhead and reacting to the mission, but could not sort out the specifics from other events. (LtCol Carl D. Matter E-Mail, 7Apr97)

Support Battalion, started the 25th still waiting impatiently at the Saudi berm for permission to push his battalion into Kuwait. He finally ordered Captain Hull's Company C to the first obstacle belt; Captain Hearnberger's Company B, which had returned to his control, to the second belt; and Captain Hatton's Company A to extend the Khanjar Expressway to the first minefield.* Skipper focused the battalion's efforts on improving all breach lanes through both obstacle belts.** The Ninja Bulldozers pushed sand and mines to the side of the road and engineers removed visible explosives, checked the lanes with metal detectors, and marked the routes. The Ninja Bulldozers performed flawlessly even when they hit mines.*** The explosions from the antitank mines only dented bulldozer blades while the blasts from all but one antitank mine just peeled back portions of the blade an inch or two. One antitank mine damaged the tread of a Ninja Bulldozer which was evacuated to Khanjar, fixed, and returned to action the next day. On the other hand, a mine destroyed a British flail bulldozer used by the engineers, and blocked a breach lane for a day. Fortunately, exploding mines caused no serious injuries to the Marines, however, a blast from one knocked Company B's indomitable Staff Sergeant Daniel A. Kur off the bulldozer he was riding.**** Kur picked himself off the ground, checked the condition of the driver, and continued to clear mines.⁵³¹***** For the remainder of the day, the battalion graded the breaches, replaced broken engineer stakes, and recovered vehicles either damaged during the assault or by straying outside the marked lanes.⁵³²*****

The 1st Marine Division Zone of Action

The 25th started early for Captain Winter's MCSSD-17 Marines and for DSG-1. After resupplying Ripper on the 24th, the mobile was low on fuel and

*Col Skipper commented that, "A great sight I will always treasure occurred at approximately 0900, as my vehicle approached the first minefield belt. We passed a military police check point which displayed a hastily scrawled sign that said 'Semper Fi.' One of the military policeman held up a Playboy magazine foldout. His smile, the sign, and the foldout told me that 'the Marines had landed, and the situation was well in hand.'" (Skipper comments)

**LtCol Skipper and LtCol John D. Winchester, the commanding officer of the 2d Combat Engineer Battalion, planned the return of Company B to the control of the 8th Engineer Support Battalion "with a handshake." Skipper and Winchester had known each other since their college days at the Citadel. (Skipper comments)

***The 8th Engineer Support Battalion Ninja Bulldozers hit nine anti-personnel mines and five anti-tank mines during breach clearing operations. (Skipper comments)

****Col Skipper acknowledged the bravery of the Ninja Bulldozer drivers by saying, "They were driving an experimental item, that was not combat tested. It had gone from a concept to fielding in 60 days. Their courage was inspiring." (Skipper comments)

*****For his acts of gallantry on the 24th and 25th, SSgt Kur was presented the Silver Star Medal.

*****By the end of G+2, the 8th Engineer Support Battalion cleared 50 kilometers of road behind the 2d Marine Division. (DSC, ComdC 16Feb-13Mar91, Sec 3.)

water and needed to replenish its stocks. At 0100, Winter, knowing that Ripper was going to continue the attack at daylight and that CSSD-10 could not resupply until later in the day, sent his executive officer, First Lieutenant Shawn B. Gormish, with empty bulk-liquid trucks to OP-4 to pick-up supplies.⁵³³ A couple of hours later, Colonel Powell departed the area enroute to Khanjar to touch base with General Krulak while guides from the 1st Battalion, 7th Marines, arrived to lead a resupply mission to their position. MCSSD-17 gave the battalion 4,300 gallons of fuel, 4,000 gallons of water, batteries, and 15 TOW II missiles.⁵³⁴ At 1300, CSSD-10's scheduled resupply convoy reached MCSSD-17 and transferred 20,000 gallons of fuel, 5,400 gallons of water, and ammunition. An hour later, Lieutenant Gormish returned from OP-4 with 14,400 gallons of fuel. Delayed during the morning by an Iraqi counterattack on Task Force Papa Bear, the main body of Task Force Ripper started north in the afternoon. MCSSD-17, now well provisioned, stayed in position, pushed supplies to Task Force Ripper, and guarded 1,600 prisoners-of-war who crowded its holding area.⁵³⁵

Earlier that day, in fact at dawn, MCSSD-11's Alpha Train returned to the mobile's position south of the second line of obstacles after resupplying Task Force Grizzly, starting a morning of hectic combat service support operations. Upon its arrival, Captain Burke sent the Alpha Train at 0745 to supply Papa Bear's command element. Fifteen minutes after completing the mission, an Iraqi tank and two armored personnel carriers carrying a regimental commander emerged from the fog in front of Papa Bear's command post and surrendered. The Iraqi commander warned the Marines that the combat units following him intended to fight. Almost immediately, a 10-minute battle erupted around the regimental headquarters followed by a three-hour assault on the 1st Tank Battalion.⁵³⁶ After listening to the battle begin over the regimental tactical net, Burke led a small convoy forward with fuel and ammunition to resupply the tankers and ordered the mobile's main body to follow him in an hour. Burke moved his convoy to within 200 meters of the second obstacle belt delivering 5,000 gallons of fuel, 1,536 rounds of M60 tank ammunition, and 15 TOW missiles to the tank battalion's combat train, while the battle raged only 2,000 meters to the north and artillery and mortar rounds burst around his position. A four-round Iraqi salvo impacted 150 meters from his convoy that the 11th Marines immediately answered with an artillery barrage, silencing the enemy fires.^{537*}

Back at CSSD-13, Captain Ritchie listened to Papa Bear's engagement on the division's tactical net and decided to send TOW missiles to MCSSD-11. Thirty minutes later the CSSD-10 commander, Lieutenant Colonel Kelly, heard MCSSD-11 unsuccessfully try to request TOWs over the DSG-1 command net and in turn tried and failed to pass the request to OP-4. Disappointed and concerned by the lack of communications, Kelly noticed in the distance an antennae poking into the sky, drove to the location, and discovered an amphibious assault communications vehicle. Kelly asked to use the radio, called CSSD-10, and

*Burke commented that his resupply convoy was close enough to the battle to see turrets flying off exploding Iraqi tanks and that the effect of the Marine artillery on the enemy was an "exhilarating" experience. (Burke comments)



Photo courtesy of Maj Adrian W. Burke

MCSSD-11 passes by Iraqi armor destroyed by Task Force Papa Bear.

ordered an emergency resupply of TOW missiles for MCSSD-11. Back at OP-4, the CSSD-10 ammunition technicians, responding to both CSSD-13's request and Kelly's order, pulled TOW missiles for CSSD-13. Lieutenant Smith, CSSD-13's landing zone officer, prepared the TOW missiles for helicopter transportation and briefed the pilots on the location of their resupply mission, while Captain Brown in the operations center called over the radio the brevity code "Mackerel" (TOW Missiles), for MCSSD-11. Captain Ritchie calculated that it took only an hour and 15 minutes from when he decided to send TOWs until they reached MCSSD-11, while Lieutenant Colonel Kelly estimated that it took 30 minutes from his call until he saw two CH-53 Sea Stallion Helicopters carrying TOWs, fly over his position towards MCSSD-11.⁵³⁸

Just south of the second obstacle belt, Captain Burke waited with his empty convoy for the arrival of the main body of MCSSD-11 while receiving requests from the 1st Tank Battalion for Dragon missiles and from the 1st Battalion, 1st Marines, for resupply. The main body with its newly arrived batch of TOW missiles joined Captain Burke at noon and then established a defensive position 1,000 meters south of the second obstacle belt. From this position, the mobile resupplied the 1st Tank Battalion with 39 Dragon and TOW missiles and 2,000 gallons of water; the 1st Battalion, 1st Marines, with 42 TOW and Dragon missiles together with small arms ammunition; and the engineers with 3,900 gallons of fuel. Meanwhile, Colonel Powell, after missing General Krulak at Khanjar, returned to the battlefield and ordered Captain Morsch and Ensign Handcock to move the retransmission site and the medical mobile back to the first obstacle belt and to reestablish communications which were lost during the night. Morsch executed Powell's order and reestablished communication within DSG-1 and with Task Forces Grizzly and Taro.

After dispatching the resupply trains to Papa Bear, Captain Burke sent a request to DSG-1 for fuel, water, ammunition, and a medevac for 12 wounded Marines and Iraqis at Papa Bear's regimental aid station. Thirty minutes later and

just beating the fog that drifted into the area, two CH-46 Sea Knight helicopters evacuated the casualties. The ammunition resupply was canceled, however, until the weather improved. Burke ordered MCSSD-11 to dig in for the night, and at 2000, dispatched Lieutenant Williams with the Alpha Train to resupply the 3d Battalion, 9th Marines. Missing the battalion's logistics train in the fog, Williams found its combat train near the battalion's forward positions just as a firefight broke out. The infantrymen ordered the Alpha Train out of the area, but recalled it after the battle was over. During the second attempt to resupply the battalion, the Iraqis struck again. The infantrymen circled the Alpha Train with amphibious assault vehicles and tanks and repelled the Iraqis. Lieutenant Colonel Michael H. Smith, the battalion commander, concerned with the safety of the Alpha Train Marines, ordered them down from their exposed and elevated ring-mounted machine guns on their trucks. Mortar rounds fell around the position and small arms zinged through the area. The Alpha Train remained encircled in its armored cocoon until the next day.⁵³⁹

CSSD-10 also had an active time on the 25th. Lieutenant Colonel Kelly's troops at OP-4 retrieved trucks from the 11th Marines, loaded and launched resupply convoys to MCSSDs -11 and -17, and prepared to move into Kuwait. During the previous night, most of the artillery ammunition trucks had returned from the 11th Marines except for those with the 3d Battalion, 11th Marines. Major Lucenta, CSSD-10's operations officer, then visited the battalion headquarters to

A CH-53 heavy lift helicopter with an external load, departs CSSD-13 for a resupply mission inside Kuwait.

Photo courtesy of LtCol William H. Ritchie III





Photo courtesy of LtGen James A. Brabham, Jr.

A column of CSSD-10 vehicles moves into Kuwait during the ground phase of the campaign. The vehicles are in single file to follow the tracks of the lead vehicle with the intent of avoiding mines or soft spots.

reclaim his vehicles. Between 0900 and 1600 at OP-4, Major Rice, CSSD-10's executive officer, sent forward three convoys which carried maintenance contact and salvage teams, a collecting and clearing company, graves registration personnel, engineers, ammunition technicians, the landing support detachment, 32 pallets of MREs, 47,000 gallons of water, and 40,800 gallons of fuel. Moving towards MCSSD-17's position, Colonel Powell met the convoys and led them to a point near the mobile's position for the night. At OP-4, CSSD-10 received 68,000 gallons of water and 131,000 gallons of fuel during the day.⁵⁴⁰

With CSSD-10 on the move, Captain Ritchie used CSSD-13's few trucks to move supplies from CSSD-10's dumps to his landing zone. Even with this added burden, the CSSD successfully completed its daily helicopter resupply of Task Forces Taro, Shepherd, and Grizzly as well as the emergency TOW resupply to MCSSD-11. In the evening, Captain Ritchie reviewed the situation and scheduled helicopters for the next day. At the top of the list were the 100 TOW missiles ordered during the evening by MCSSD-17.⁵⁴¹

While tank battles raged and DSG-1 resupplied itself and the division, the engineers moved forward with the 1st Marine Division. Major Musca, the commanding officer of the combat engineer detachment supporting Task Force Pappa Bear, ordered Captain Salinas' Company A, 7th Engineer Support Battalion, to build and operate an enemy prisoner of war camp. Salinas directed his bulldozers to erect a berm around an area about the size of a football field to hold 1,250 prisoners. During the afternoon, the DSC engineers quit their jobs as jailers when Musca ordered them to move forward behind the 1st Tank Battalion to an assembly area near the Al Burqan Oil field.⁵⁴² Behind Task Forces Papa Bear and Ripper, the 7th Engineer Support Battalion completed marking and proofing lanes through both obstacle belts.⁵⁴³

G+2: 26 February 1991

After refueling and replenishing during the night and early morning hours, I MEF continued to attack north on 26 February. Its objectives were Kuwait International Airport and the Al-Mut' a Pass (Al-Jahrah).⁵⁴⁴

The second day of the ground war ended with both divisions advancing north after repelling morning counterattacks by the Iraqis. On the morning of the 26th, I MEF's assault regiments and task forces focused on their final objectives and prepared to attack. To support both divisions' northerly movement, the DSC planned to establish a transfer point at Al Jaber Airbase, which the 1st Marine Division isolated on the 24th and 25th in preparation for the foot-mobile Task Force Grizzly to clear on the 26th. Both DSG-2 and CSSD-10 aimed to project elements north of Al Jaber to support the attacks on Al Jahrah and Kuwait International Airport, respectively. The first two days of the war had produced few casualties, but had generated hordes of surrendering Iraqis creating control and evacuation problems for both the 1st FSSG and the DSC. On the western flank, General Keys prepared to seize Al Jahrah, advancing with the Tiger Brigade on the left, the 8th Marines on the right, and the 6th Marines in the middle.

The 2d Marine Division Zone of Action

After dawn on the 26th, Major Clarke, MCSSD-26's executive officer, led Serial 2 north of the Abdullea road where it joined Serial 1 and together prepared to support the 6th Marines' final attack of the war. Believing there was time before the attack, Lieutenant Colonel Wittle sent refuelers and water trucks to both the 1st Battalion, 6th Marines, and the 8th Tank Battalion, ordered that the ammunition received on the previous day be split into battalion packages, and directed that the neighboring Iraqi bunkers be cleared. The security sweep produced three enemy prisoners, weapons, and ammunition while discovering the carcass of a crashed Marine Corps Harrier jet. MCSSD-26 reported these discoveries to DSG-2. Concurrently, the mobile's doctor, Navy Lieutenant Kenneth R. Collington, began operating on a wounded Marine in the back of an ambulance. In the midst of these activities, the regimental operations officer, Major Jack K. Sparks, Jr., ordered MCSSD-26 to move immediately to support the attack.

Instantly, Lieutenant Colonel Wittle had a number of things to do before moving. Almost simultaneously, he ordered the ammunition reloaded on trucks, requested that the regimental S-4, Captain Lorine E. Bergeron III, designate which units would get the munitions, urged Collington to hurry the surgery, and tried to recall the two resupply convoys. Bergeron replied that the ammunition should go to the 2d Battalion, 2d Marines, and Wittle then sent his munitions trucks to the battalion's logistics train. Failing to contact the resupply missions and unhappy with the idea of abandoning his Marines, Lieutenant Colonel Wittle sent Second Lieutenant Kelley, the motor transport officer, to find the refuelers.

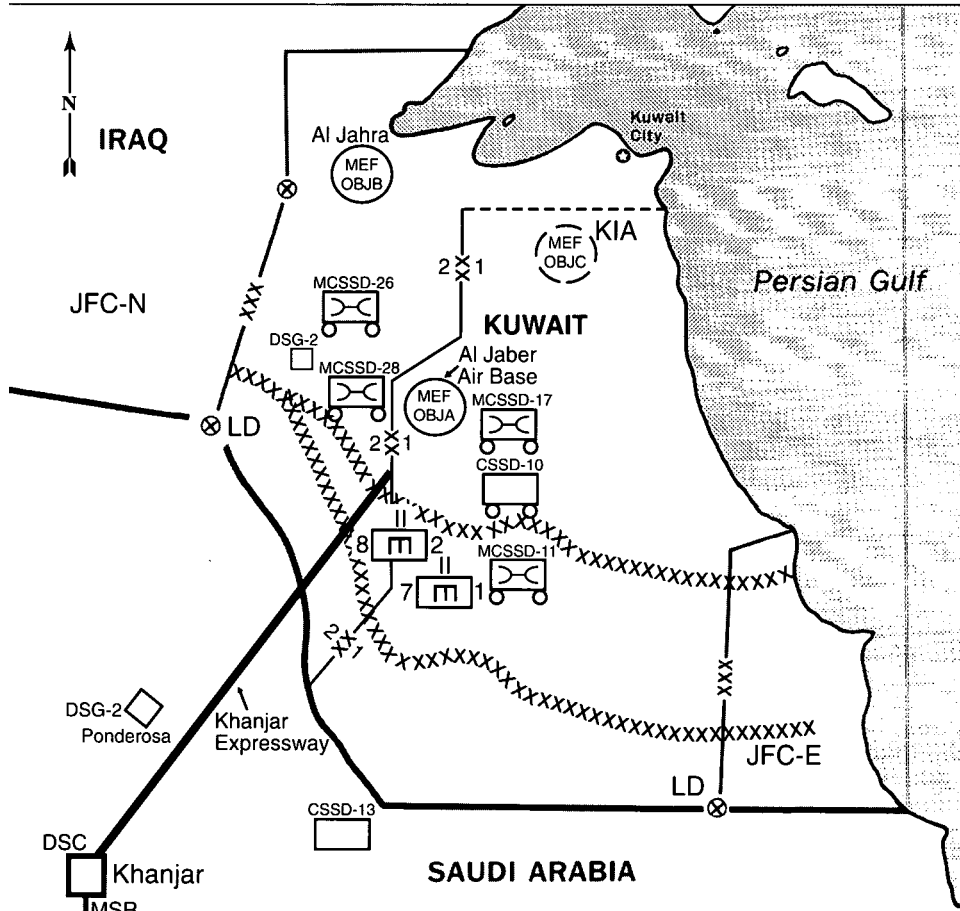

DSC Positions at the Beginning of G+2: 26 February 1991

After several more attempts to contact them by radio and on completion of the medical procedure, Wittle reluctantly ordered MCSSD-26 forward and left Captain Warker, the operations officer, behind to wait for Kelley and the orphaned resupply convoys. Just as the mobile was about to disappear from sight, Lieutenant Kelley appeared from behind a cloud of dust with the lost convoys and rejoined the main body of the MCSSD.⁵⁴⁵

On the 26th, the situation improved somewhat for Lieutenant Colonel Hering at DSG-2's northern transfer point. During the early morning hours, Lieutenant Colmenares, with his collecting and clearing station, had arrived at the transfer point and Hering immediately sent him to the Ponderosa with all of the empty bulk-liquid trucks. Colmenares returned later in the morning with fuel and water. Hering informed MCSSD-28 that supplies were available, but that they would have to be picked up at the transfer point.⁵⁴⁶ He then sent the bulk-liquid trucks back to the Ponderosa for more provisions and ordered that the convoy's communication vehicle be left at the breach to reestablish contact with the Ponderosa. After restoring communications with the rear, Hering was astonished to learn that the DSG-2 was preparing to relocate into Kuwait. He believed this